

Dedicated Feeders for IPs Using Solar Based Generation

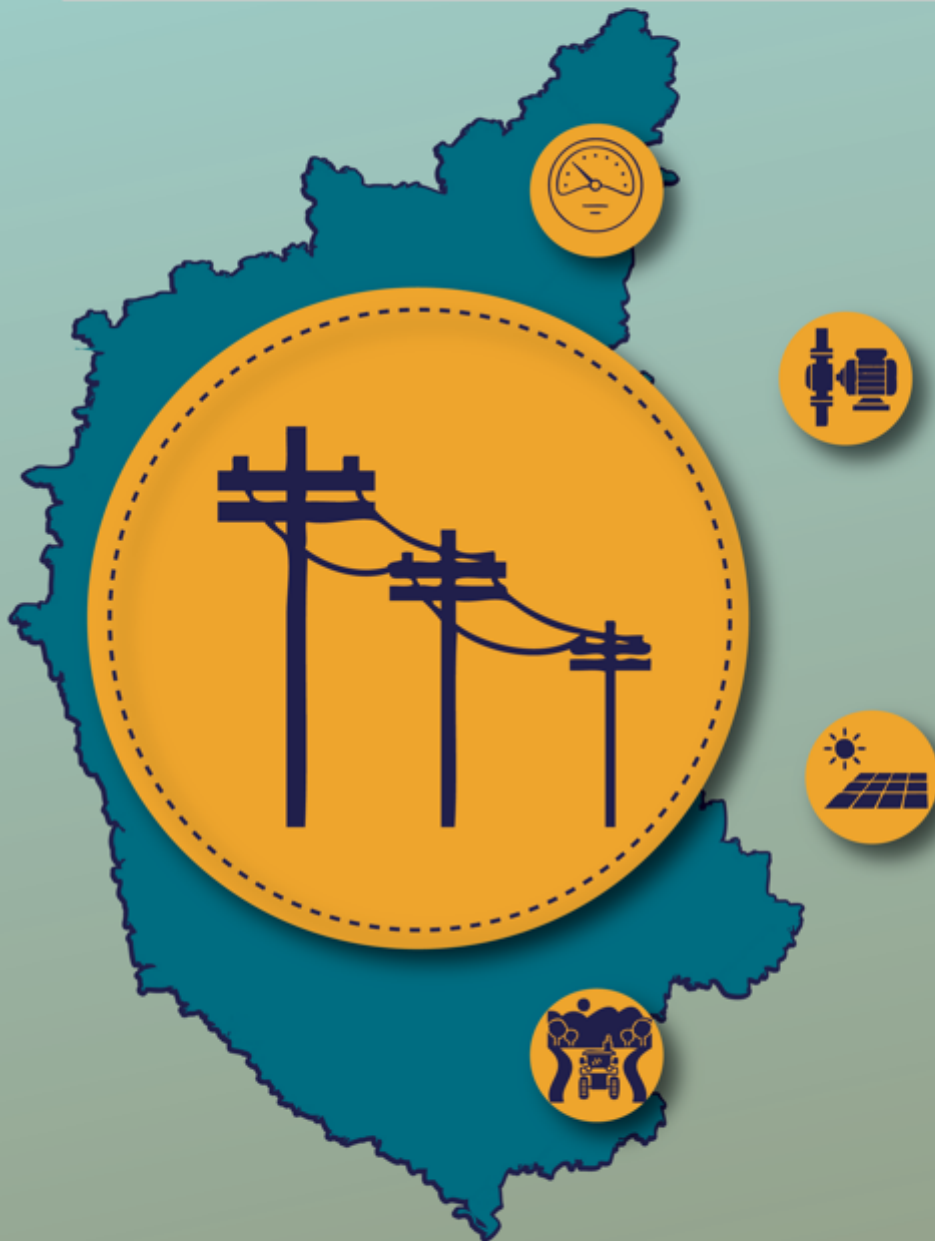

Dedicated Feeders for IPs Using Solar Based Generation

Final Report

Submitted by: Center for Study of Science, Technology and Policy (CSTEP)

For: The Energy Department,

Funded by: The Planning Department, Government of Karnataka

July, 2018

Center for Study of Science, Technology and Policy (CSTEP) is a private, not-for-profit (Section 25) Research Corporation registered in 2005.

Designing and Editing by CSTEP

Disclaimer

While every effort has been made for the correctness of data/information used in this report, neither the authors nor CSTEP accept any legal liability for the accuracy or inferences for the material contained in this report and for any consequences arising from the use of this material.

© 2018 Center for Study of Science, Technology and Policy (CSTEP)

For private circulation only.

July, 2018

Center for Study of Science, Technology and Policy

#18, 10th Cross, Mayura Street,

Papanna Layout, Nagashettyhalli, RMV II Stage,

Bangalore-560094 Karnataka, INDIA

Tel.: +91 (80) 6690-2500

Fax: +91 (80) 2351-4269

Email: cpe@cstep.in

Website: www.cstep.in

Acknowledgements

CSTEP expresses its gratitude to Shri. P. Ravi Kumar, IAS, Additional Chief Secretary, Department of Energy, Government of Karnataka (GoK) for all his support in this project. The authors would like to thank Shri. Govinda Raju, Additional Director, Department of Energy, GoK, for his valuable inputs and constant guidance. CSTEP researchers wish to thank Shri. Chandra Shekhar (Executive Engineer) and Smt. Sneha of the State Load Dispatch Centre for providing relevant SCADA data. The authors thank the Managing Directors, Technical Directors and entire staff at BESCOM, CESC, GESCOM, HESCOM, HRECS and MESCOM for sharing the information and valuable insights for this study.

CSTEP is grateful to Shri. D. Nagaraj (Managing Director) and Shri. T. Maruti (Asst. General Manager) from KREDL for arranging site visits and choosing plants for pilot projects. In this regard, CSTEP would also like to thank Shri. Krishna Rajendra (Technical Consultant) and Smt. Jyoti (Addl. General Manager, DSM Section) from BESCOM for coordinating the visits and assisting in obtaining data.

The authors gratefully acknowledge the inputs and valuable suggestions by project advisors Shri. Sumanth Shankar Rao, Dr Sreenivasa Murthy and the Quality Control team at CSTEP. The authors also wish to thank Vaishalee Dash, Sandhya Sundararagavan, Harikrishna K. V., Bharath Ranganath and Yuvaraja S. K. for their assistance in technical and IT aspects of the project.

Last but not least, this work would not have been possible without the valuable support and encouragement from Dr Anshu Bharadwaj, Executive Director, Dr Jai Asundi, Research Coordinator and Thirumalai N.C., Project Manager.

Executive Summary

The agricultural sector in Karnataka accounts for 39% of the state's electricity (~21,344 MU). This is provided for free, or at heavily subsidised rates, to farmers. Moreover, electricity is not metered. This has led to an estimated revenue loss of INR 9,295 crores for the state DISCOMs. The Government has attempted several initiatives to reduce this loss. One option being followed is segregation of domestic and agricultural feeders. This enables regulating power supply to agricultural consumers and providing 24X7 power to domestic consumers. This has been implemented in 4,364 feeders out of a total of ~6,078 mixed feeders in the state.

The feeder separation provides an opportunity for use of solar energy to supply electricity to agricultural feeders. Karnataka not only has good solar radiation profile but is also a leading state in solar installations with a commissioned capacity of ~5.1 GW. This is expected to cross 10 GW by 2025. Therefore, there is a case to examine viability of solar power for supplying dedicated agricultural feeders (DAFs).

The Energy Department requested CSTEP to assess the technical and economic feasibility of supplying the DAFs with solar-based generation. The objective is to determine whether existing and proposed PV plants (1-5 MW) can supply these feeders directly, thereby reducing losses and increasing accountability in terms of metering. CSTEP undertook this study and analysed various system designs to construct an implementable roadmap with policy recommendations for the Energy Department.

CSTEP considered 5 system design options, of which 3 are off-grid and 2 are grid connected. These are tabulated as below:

- ***Case 1: Off-Grid PV Plant with Battery Storage***
- ***Case 2: Off-Grid PV Plant with Water Storage***
- ***Case 3: Off-Grid PV Plant with Battery Storage and Scheduling***
- ***Case 4: Grid-Connected PV Plant with One-Way Export to Grid:*** This further included 3 storage options: battery, battery and scheduling, and water storage.
- ***Case 5: Grid-Connected PV Plant with Import/Export Option:*** This included 2 options: feeder at LT side of substation and feeder at HT side of substation.

The project conducted a detailed techno-economic analysis of the above mentioned 5 system designs. The levelised cost of electricity (LCOE) is provided in the table below.

	<i>Off-Grid PV (Case 1-3)</i>			<i>Grid-Connected with One-Way Export (Case 4)</i>			<i>Grid-Connected with import/export option (Case 5)</i>	
System Design	Battery Storage	Battery Storage & Scheduling	Water Storage	Battery Storage	Battery Storage & Scheduling	Water Storage	Feeder at LT Side of Substation	HT Side of Substation
LCOE (INR /kWh)	11-25	12-30	9-12	7-17	6-23	5.5-8	4-5	3.8-4.7
Comments	<ul style="list-style-type: none"> • Too expensive • Scheduling has political and social acceptance issues 			<ul style="list-style-type: none"> • Reverse power relays are not present in the distribution sector till date • Water storage possible only in places with river/canal-based irrigation 			<ul style="list-style-type: none"> • Issues of inaccurate metering • DISCOMs need to be more co-operative and proactive 	

The main findings of the report are as follows:

- Based on the above, off-grid PV systems are too expensive because of the high cost of energy storage. Grid connected option with one-way export is also not economical. However, grid connected with import/export is economically feasible and can be implemented in the state.
- The Government can choose 10% of the existing DAFs across DISCOMs. 5% of these can be connected to existing solar plants connected at the HT side and the other 5% can be connected directly to existing Farmers' Scheme plants (1-3 MW) at the LT side of the respective substations. These pilots can then be monitored for two years to check whether metering protocols are being adhered to and there is substantial increase in accountability and reduction in losses for DISCOMs.
- Two other feeders can be chosen to test the feasibility of using off-grid PV with water/battery storage and one-way export to the grid with innovative relay technologies. One feeder can be in an area with river and canal-based irrigation practices (water storage option) and the other can be in any DISCOM area.
- DISCOMs will need to co-operate in terms of maintaining accurate meter readings and providing support to the solar developers who will connect to the feeders directly.
- Farmers will need to be more proactive when it comes to providing updated information regarding their IP sets and also pay a nominal rate of INR 0.25-0.5/kWh.
- Regular audits and inspections need to be undertaken by independent third-party organisations in order to provide objective and unbiased reports/recommendations/evaluations of the progress of such a programme.

KREDL, Energy Department, KERC and DISCOMs need to work in a collaborative manner to ensure the success and sustainability of such a programme.

Table of Contents

Acknowledgements	5
Executive Summary	7
Abbreviations & Acronyms	11
1. Introduction	12
2. Theory of Change	17
3. Progress Review	21
4. Problem Statement	23
5. Study Design and Methodology	24
6. Data Collection and Analysis	33
7. Findings and Discussion	41
8. Reflections and Conclusion	51
9. Recommendations	56
Bibliography	60
Annexures	64
Appendix I – Efforts in Other States	65

List of Figures

Figure 1: Share of electricity consumption among DISCOMs in Karnataka.....	13
Figure 2: Share of electricity consumption among consumer categories in Karnataka.....	13
Figure 3: DISCOM-wise share of IP sets in Karnataka.....	14
Figure 4: Total consumption of IP sets among DISCOMs in Karnataka.....	14
Figure 5: Specific annual consumption per IP set among DISCOMs in Karnataka.....	14
Figure 6: Share of total subsidy claimed by DISCOMs in Karnataka for supplying power to the agricultural sector.....	15
Figure 7: Subsidy claimed by DISCOMs in Karnataka per unit of power supplied to the agricultural sector.....	15
Figure 8: Study framework.....	17
Figure 9: Workflow for project.....	18
Figure 10: Share of DAFs among DISCOMs in Karnataka.....	22
Figure 11: Status of segregation of IP sets among DISCOMs in Karnataka.....	22
Figure 12: Off-grid PV with battery storage to supply DAF.....	25
Figure 13: Off-grid PV with surface water reservoir to supply DAF.....	26
Figure 14: Off-grid solar with battery and scheduling to supply two or more DAFs.....	27
Figure 15: PV with storage to supply DAF and one-way export to grid.....	28
Figure 16: Grid-connected PV plant connected directly to DAF at LT side of substation.....	29
Figure 17: Grid-connected PV plant connected at HT side of substation to supply DAF.....	30
Figure 18: Study methodology to assess feasibility of solar for agricultural feeders.....	32
Figure 19: Actual load curve of F2-Malligere DAF on 1st January, 2017.....	35
Figure 20: Representative reconstructed load curve for a DAF in Karnataka.....	36
Figure 21: Representative annual load curve for a DAF in Karnataka.....	36
Figure 22: HOMER simulations for off-grid PV with battery storage.....	37
Figure 23: ETAP simulation for grid-connected PV for F2-Malligere feeder.....	38
Figure 24: PVSyst report for 3 MW PV plant for F2-Malligere feeder.....	39
Figure 25: DARPAN visualisation platform for DAFs in Karnataka with PV plants.....	40

List of Tables

Table 1: Research framework for study.....	19
Table 2: Format for substation-level data.....	33
Table 3: Format for feeder-level data.....	33
Table 4: Format for solar plant details.....	33
Table 5: Sample SCADA data of Banangadi substation.....	35
Table 6: Economics of system designs to supply DAFs in Banangadi substation only with solar-based generation.....	41
Table 7: Economics of system designs to supply DAFs in Banangadi substation with grid-connected PV plants.....	46
Table 8: SWOT analysis of system design options to supply DAFs in Karnataka with solar-based generation.....	48

Abbreviations & Acronyms

APEPDCL	Andhra Pradesh Eastern Power Distribution Company Limited	IPDS	Integrated Power Development Scheme
APPC	Average Pooled Power Purchase cost	JGY	Jyoti Gram Yojana
APSPDCL	Andhra Pradesh Southern Power Distribution Company Limited	KERC	Karnataka Electricity Regulatory Commission
ARR	Annual Revenue Requirement	KPTCL	Karnataka Power Transmission Corporation Limited
AT&C	Aggregate Technical and Commercial	KREDL	Karnataka Renewable Energy Development Limited
BESCOM	Bangalore Electricity Supply Company	KRSRAC	Karnataka State Remote Sensing Application Center
CESEC	Chamundeshwari Electricity Supply Company	KUSUM	Kisan Urja Suraksha evam Utthaan Mahabhiyan
DAF	Dedicated Agricultural Feeder	kV	kilovolt
DARPAN	Decision Analysis for Research and Planning	kVA	kilovolt ampere
DDUGJY	Deen Dayal Upadhyaya Gram Jyoti Yojana	kVAR	kilovolt ampere reactive
DISCOM	Distribution Company	kW	Kilowatt
DNI	Direct Normal Irradiance	kWh	kilowatt hour
EFR	Earth Fault Relay	LCOE	Levelised Cost of Electricity
EIA	Economic Impact Assessment	LT	Low Tension
ETAP	Electrical Transient and Analysis Program	LULC	Land Use/Land Classification
FRP	Feeder Renovation Program	MESCOM	Mangalore Electricity Supply Company
FY	Financial/Fiscal Year	MU	million units
GDP	Gross Domestic Product	MVA	Megavolt ampere
GESCOM	Gulbarga Electricity Supply Company	MW	Megawatt
GFSS	Gaothan Feeder Separation Scheme	NIWE	National Institute of Wind Energy
GHI	Global Horizontal Irradiance	NJY	Niranthara Jyoti Yojane
GIS	Geographic Information System	NREL	National Renewable Energy Laboratory
GoK	Government of Karnataka	OCR	Over Current Relay
GSDP	Gross State Domestic Product	PPA	Power Purchase Agreement
HESCOM	Hubli Electricity Supply Company	PV	Photovoltaic
HOMER	Hybrid Optimisation Model for Electric Renewables	PVSystem	Photovoltaic System Software
HP	horsepower	SCADA	Supervisory Control And Data Acquisition
HRECS	Hukkeri Rural Electric Co-operative Society	SERC	State Electricity Regulatory Commission
HT	High Tension	SLDC	State Load Dispatch Centre
INR	Indian Rupee	SWOT	Strengths Weaknesses Opportunities Threats
IP	Irrigation Pump	USD	American Dollar

1. Introduction

1.1. Background

Karnataka's total electricity consumption is around 54,183 million units (MU) (Figure 1). Out of this, the agricultural sector consumes nearly 39% (~21,344 MU) of the state's electricity. (Figure 2). DISCOMs have provided this power at heavily subsidised rates or for free to irrigation pump (IP) sets which form the bulk of the agricultural demand. This has led to a revenue loss for DISCOMs of ~INR 9,295 crores which needs to be compensated by the Government (KERC 2018b, 2018c, 2018d, 2018e, 2018f, 2018g).

The Energy Department estimates the total number of IP sets in the state to be around 24.77 lakhs and the revenue loss from each of these around INR 50/day. The total number of IP sets and their total and specific annual electricity consumption in each DISCOM are provided in Figure 3, Figure 4 and Figure 5 respectively. Although BESCOM has the highest number and consumption when it comes to IP sets, the specific annual electricity consumption per IP set is lower than CESC, GESCOM and HESCOM. The share of the subsidy and the subsidy per unit claimed by each DISCOM for supplying power to the agricultural sector are shown in Figure 6 and Figure 7 respectively. According to internal estimates, the highest share of the subsidy (35%) goes to HESCOM followed by BESCOM (22%), GESCOM and CESC (17% each), MESCOM (8%) and HRECS (1%). However, BESCOM claims the least subsidy per unit (INR 2.86/kWh) because of the high number of industrial and commercial consumers paying cross-subsidy charges whereas HESCOM and GESCOM claim north of INR 5/kWh and others between INR 4.6-5/kWh.

DISCOM-wise share of electricity demand (Total - 54,183 MU)

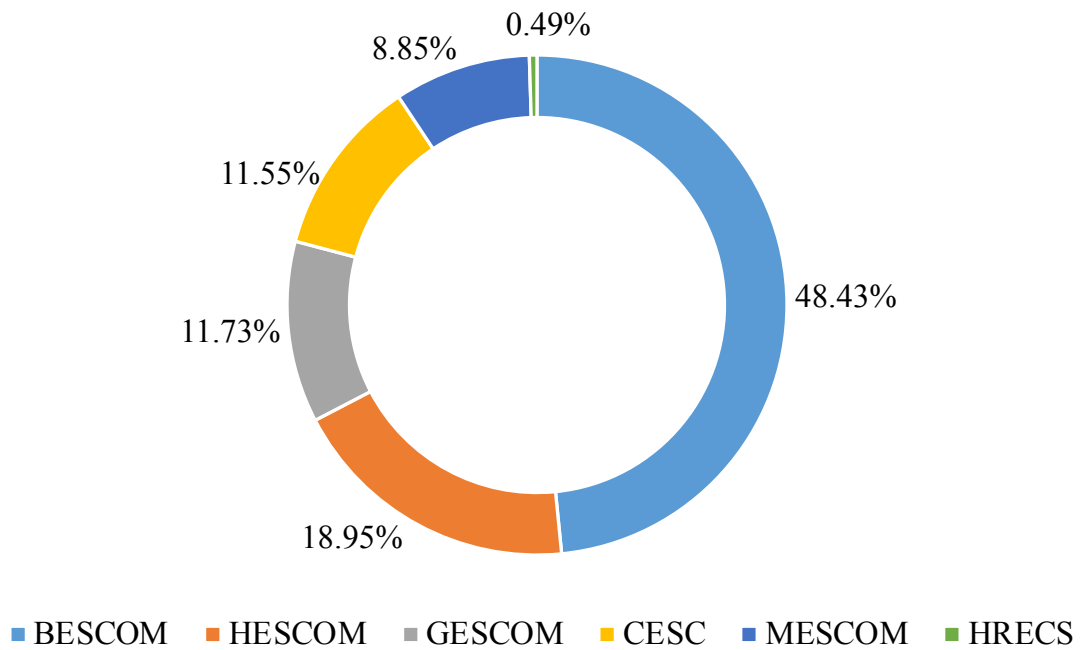

Figure 1: Share of electricity consumption among DISCOMs in Karnataka

■ Agricultural ■ Domestic ■ Commercial ■ Industrial ■ Others

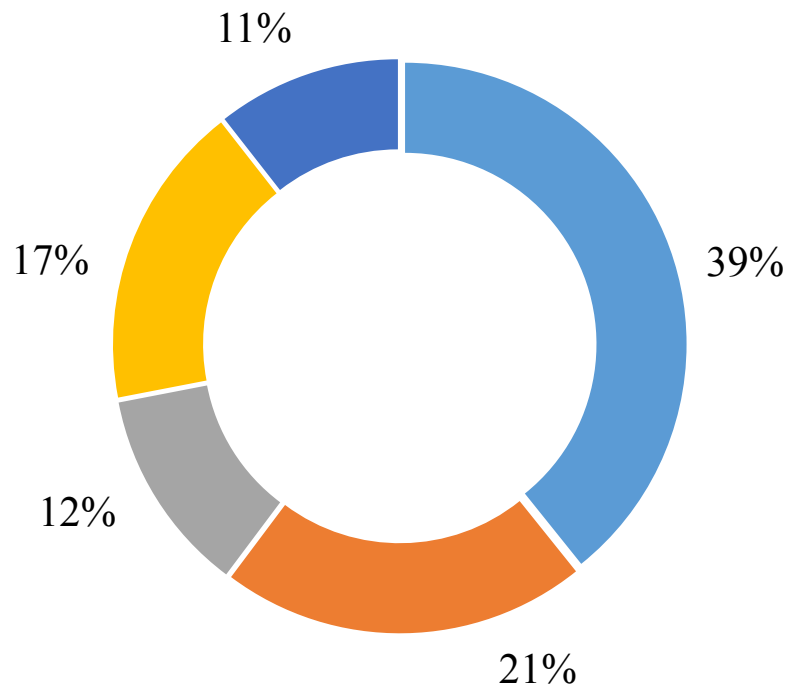

Figure 2: Share of electricity consumption among consumer categories in Karnataka

IP sets in DISCOMs

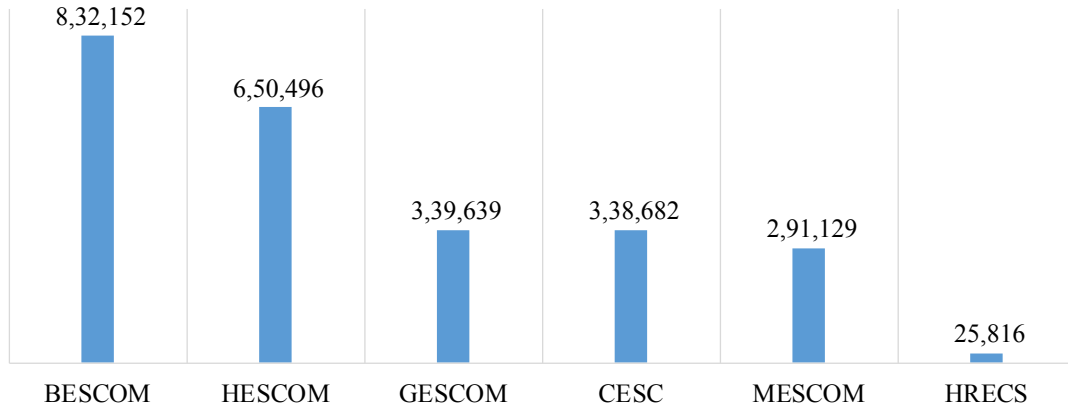

Figure 3: DISCOM-wise share of IP sets in Karnataka

Total electricity consumption by IP sets

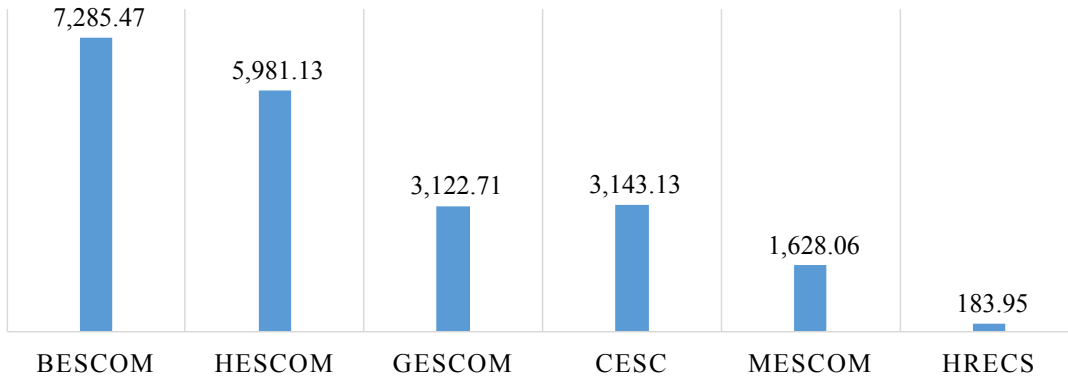

Figure 4: DISCOM-wise consumption of IP sets

Annual consumption per IP set (kWh/year)

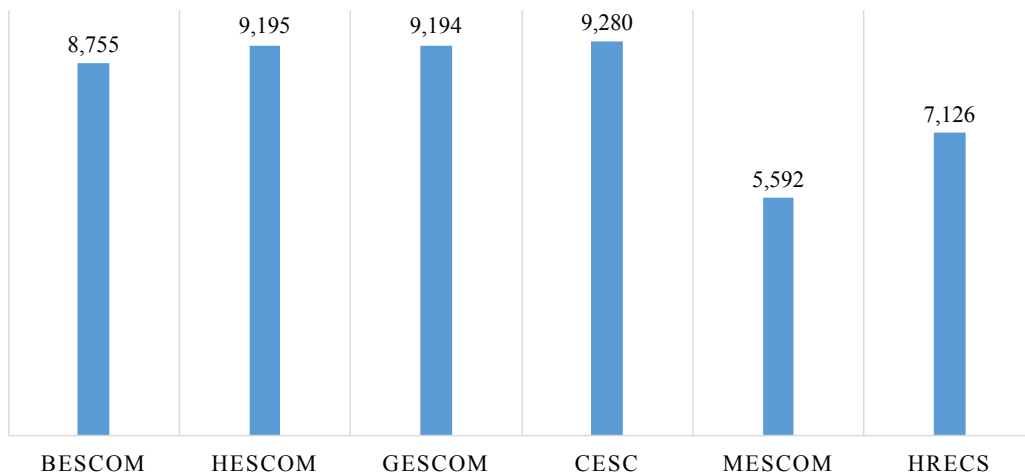
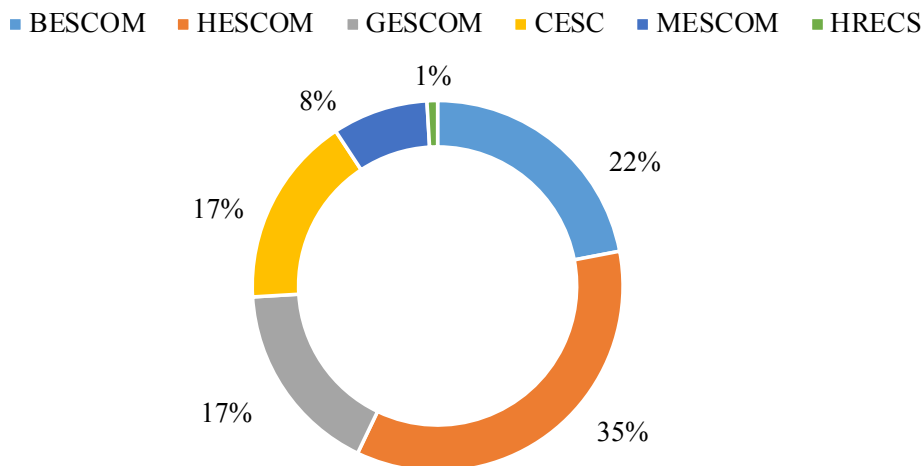

Figure 5: DISCOM-wise specific annual consumption per IP set



Share of subsidy amongst DISCOMs (Total - ₹ 9,295 cr.)

Figure 6: Share of total subsidy claimed by DISCOMs in Karnataka for supplying power to the agricultural sector

Subsidy claimed (₹/kWh) by DISCOMs for IP sets

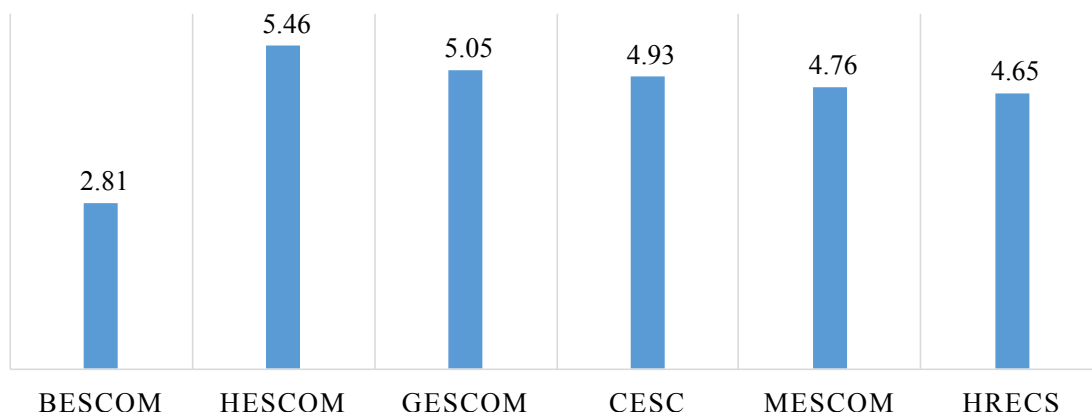

Figure 7: Subsidy claimed by DISCOMs in Karnataka per unit of power supplied to the agricultural sector

The Government has attempted several initiatives to reduce losses and improve financial viability of DISCOMs. One such scheme is to segregate agricultural and rural feeders. This will enable DISCOMS to regulate power supply to agricultural consumers and provide uninterrupted supply to domestic consumers. This process is underway in most DISCOMs and more than 4,364 dedicated agricultural feeders (DAFs) have been segregated already. The Government expects that DISCOMs will segregate all their respective agricultural feeders by 2018-19. A key step is to **implement local generation, purchase and sale of power for these agricultural feeders**, which will be economical for DISCOMs as it will reduce the AT&C losses and thereby reduce incurring of financial losses.

A promising option is to use solar power for supplying electricity to agricultural feeders. Karnataka has good solar radiation profile and is among the leading states in solar installations with about 5.1 GW installed. Therefore, there is a case to use solar for providing electricity to these agricultural feeders.

1.2. Objectives

This study explores the engineering economic feasibility of using solar power to supply agricultural feeders. The specific objectives of this project are as follows:

- To consider 5 system design options for solar-based agricultural feeders –
 - **Case 1: Off-Grid PV Plant with Battery Storage** – Pure off-grid solar with battery to ensure that only solar-based generation is supplied to DAFs
 - **Case 2: Off-Grid PV Plant with Water Storage** – Pure off-grid solar with water storage instead of a large battery ensuring that only solar-based generation is supplied to DAFs
 - **Case 3: Off-Grid PV Plant with Battery Storage and Scheduling** – Pure off-grid solar with battery with each system supplying more than one DAF on a scheduling basis
 - **Case 4: Grid-Connected PV Plant with One-Way Export to Grid:** This design considers any excess generation in the previous three designs to be exported to the grid while ensuring that only solar-based generation is supplied to DAFs
 - **Case 5: Grid-Connected PV Plant with Import/Export Option:** This includes 2 options – feeder at LT side of substation and feeder at HT side of substation. In this design, the grid serves as the backup instead of battery or water storage and either imports excess electricity generation from the PV plant or exports to DAFs when there is a deficit in solar-based generation.
- To determine the capacities (MW) and costs of solar PV plants required in most agricultural feeders.
- Techno-economic viability of the above mentioned 5 systems
- To develop an implementable roadmap with policy recommendations and innovative business models

2. Theory of Change

There appears to be a case to use solar power – which is cheaper than APPC of DISCOMs – to supply agricultural feeders in Karnataka. This has the potential to reduce financial and AT&C losses for DISCOMs. This is because power will be generated close to load centres and be consumed locally as well. It is crucial to identify suitable locations for distributed decentralised solar plants, based on demand assessments, to reduce length and cost of power transmission. Identifying substations with outgoing agricultural feeders, assessing the demand, as well as analysing the solar resource potential and availability of land, will need strategic planning and mapping of solar plants to supply IP feeders. Well-organised maintenance of such a system can boost financial sustainability of DISCOMs by decreasing revenue loss and increasing power supply for farmers.

Injection of power to feeder can be done through several methods which have been analysed in this study. Figure 8 below represents the study framework for this project with different cases for utilising available data and selecting optimal ways of injecting power to feeders and the respective financial benefits for DISCOMs and the Energy Department.

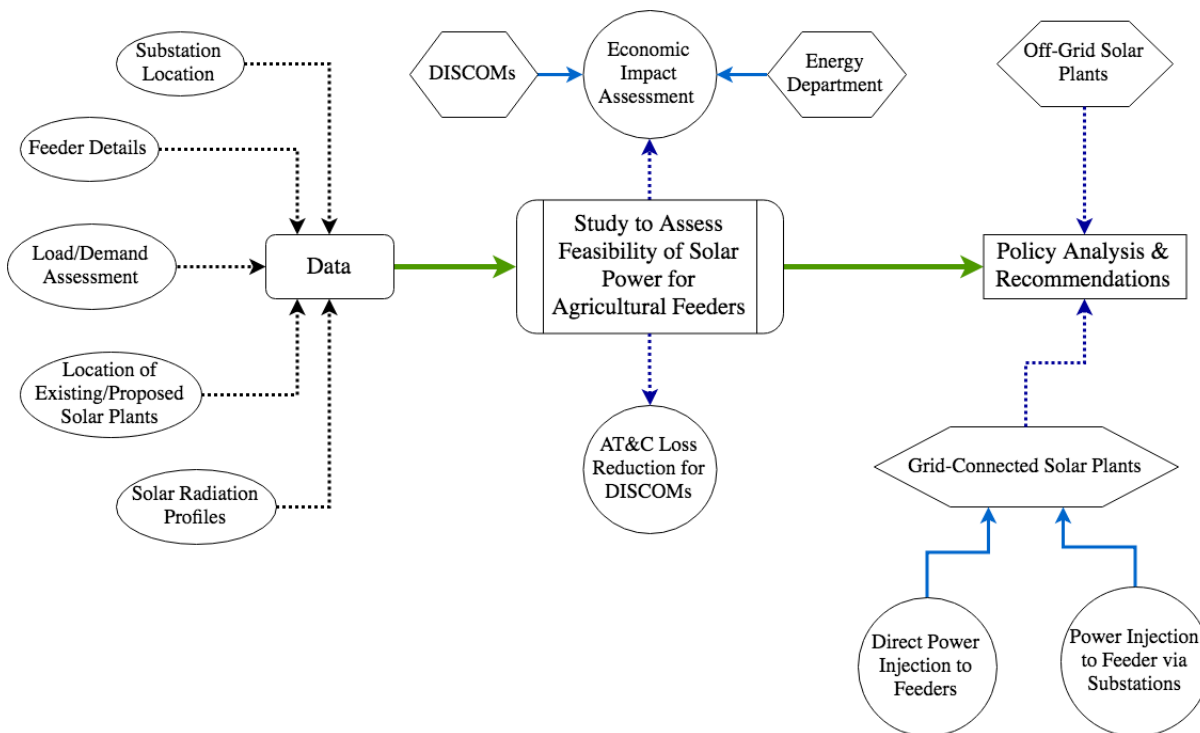

Figure 8: Study framework

2.1. Flowchart for Study

The flowchart for the study is shown below in Figure 9.

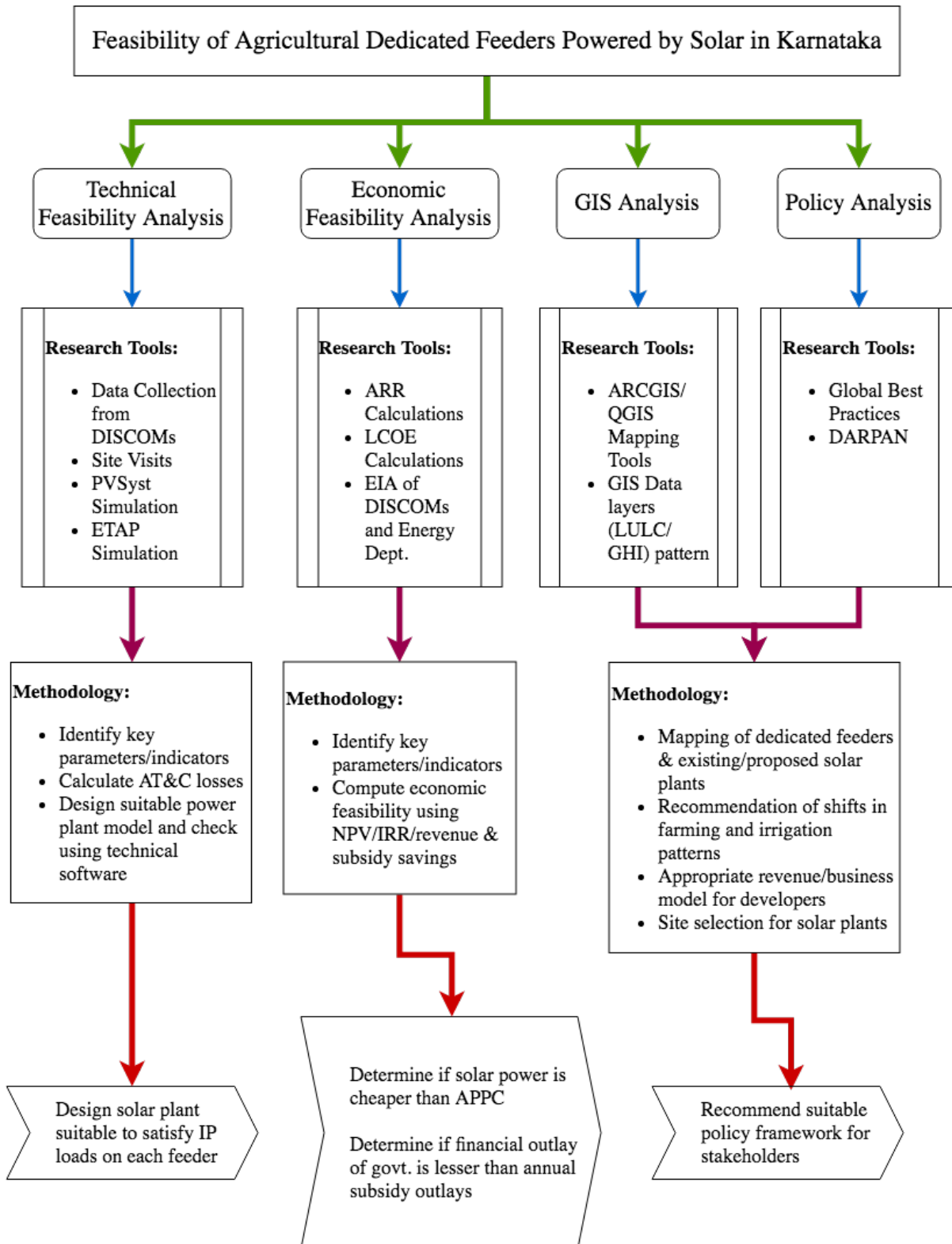

Figure 9: Workflow for project

2.2. Log Frame

The overall log frame for this study is presented in Table 1.

Table 1: Research framework for study

	Purpose	Scope	Objective	Expected Outcome	Risk/Limitation	Base line	Stake holders
Technical Analysis	To provide solar power supply to IP sets during the day	<ul style="list-style-type: none"> For IP feeders of all the DISCOMs in Karnataka. Reducing peak demand on generating stations. 	To simulate the power flow from solar plants to feeders	<ul style="list-style-type: none"> Implementation of solar plants for agricultural feeders in Karnataka Reduction in peak load patterns of DISCOMs 	<ul style="list-style-type: none"> Required solar power availability throughout the year Unmetered and un-authorized IP sets 	Existing IP feeder substation wise load data & agricultural consumption data of DISCOMs in Karnataka	DISCOMs and Energy Department, GoK
Economic Analysis	To ensure if solar plant is economical to power the agricultural feeders	Taluk wise generation of solar power	To recommend suitable business model for developer and DISCOMs	PPAs at suitable rates between developers and DISCOMs	PPA rates of allotted projects in Karnataka so far are higher than APPC of DISCOMs	Existing details from tariff orders of DISCOMs	

GIS Analysis	To know the solar radiation profiles for generation projections Spatial mapping of DAFs	Locations where solar plants are either existing or proposed for installations	To determine the capacity of the solar plant using solar radiation profile	Optimal siting of solar plants and	<ul style="list-style-type: none"> Lack of land ownership data Unauthorised IP sets locations and capacities 	GHI/DNI profiles from NREL/NIWE databases GIS layers data from Bhuvan/ KRSAC	
Policy Analysis	To provide recommendations with policy framework	For KERC and DISCOMs to adopt this scheme	ARR calculations Impact on DISCOM finances Actor network for scheme implementation	Decrease in cross subsidy regime and reduction in revenue and AT&C losses	Farmers acceptance of paying for usage of electricity	Systems engineering approach to understand stakeholder expectations and present financial structure of DISCOMs with subsidised/free electricity for agricultural sector	

3. Progress Review

Feeder segregation to have DAFs has been completed in the states of Gujarat, Andhra Pradesh, Rajasthan, Maharashtra, Punjab, Haryana and Madhya Pradesh. Similar efforts have been initiated in the states of Telangana and Karnataka. The thought process of the respective state governments behind this action was to avoid oversupply to the agricultural sector and manage water availability from a sustainability perspective, whilst providing 24X7 power for non-agricultural purposes (PowerLine 2017). This is a part of the central government's efforts under the Deendayal Upadhyaya Gram Jyoti Yojana (DDUGJY) scheme where the centre provides 60% of the project costs (85% to special category states), DISCOM or state government provides 10% (5% in special category states), and bank loans account for 30% (10% for special category states) (REC 2015). A total outlay of INR 43,000 crores has been envisaged by the centre for feeder segregation (Livemint 2014). The efforts in states apart from Karnataka are described in Appendix I – Efforts in Other States.

3.1. Karnataka: Niranthara Jyoti Yojane (NJY)

GoK initiated this scheme in 2008-09 to separate the agricultural and non-agricultural loads. The objective was to have more accountability in terms of electricity consumption and subsequent compensation for the agricultural sector. The objective was to provide 24X7 power to non-agricultural loads in rural load centres and 7-8 hours of power supply to DAFs based on supply availability in staggered phases (4 hours during daytime and 3 hours late at night). The scheme is expected to cover 129 talukas with a cost of INR 2,123 crores (Energy Department 2016).

The total number of DAFs among DISCOMs in Karnataka is enumerated in Figure 10 and the number of IP sets in the dedicated feeders and in feeders which have not yet been segregated is depicted in Figure 11.

This study assumes that the remaining feeders in each DISCOM will be segregated in the near future and the remaining IP sets will then be accounted for in the DAFs for this analysis.

Total number of dedicated agricultural feeders in DISCOMs

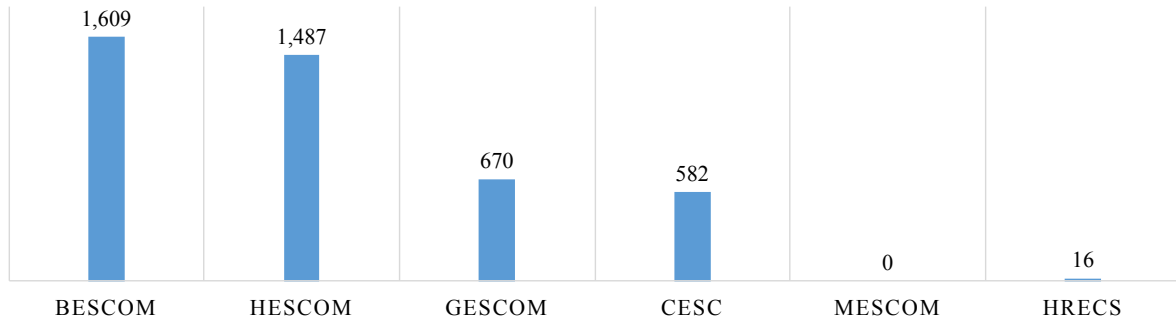

Figure 10: Share of DAFs among DISCOMs in Karnataka

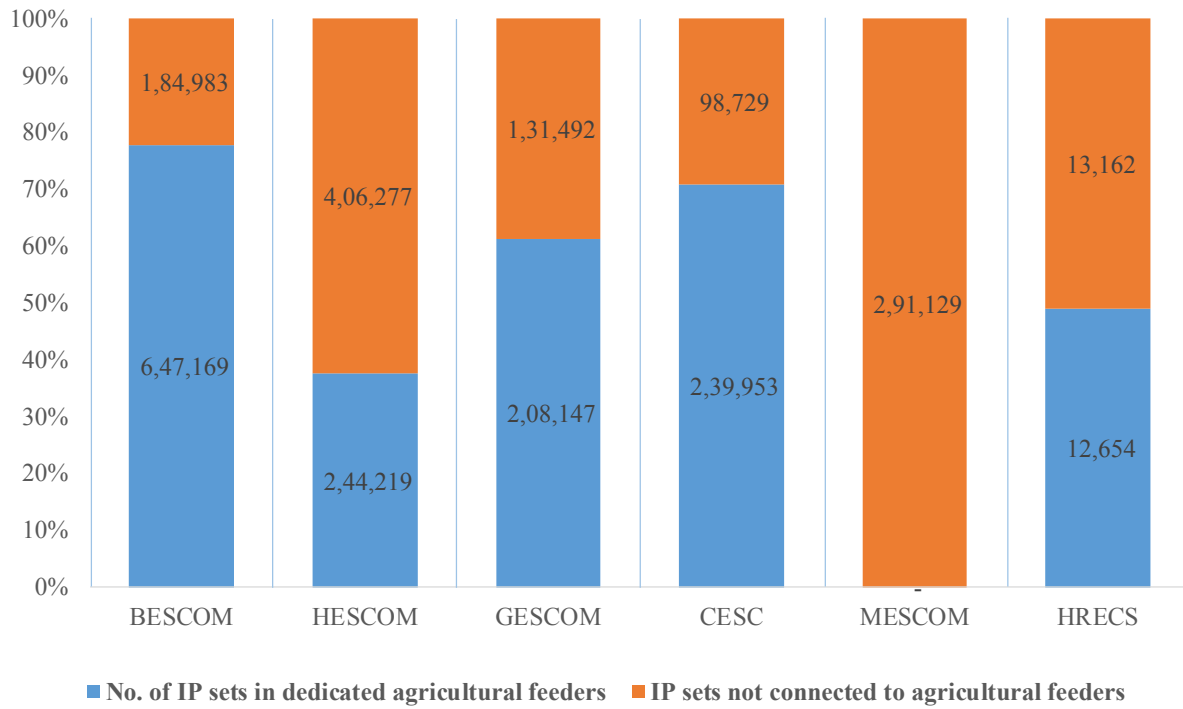

Figure 11: Status of segregation of IP sets among DISCOMs in Karnataka

4. Problem Statement

Examine the viability of using solar power to provide electricity for agricultural feeders in Karnataka.

Considering the fact that almost 39% of Karnataka's electricity consumption is an agricultural sector, it is essential to optimise the supply and minimise losses. At present, farmers have little incentive to switch off IP sets during times of no supply or when there is no requirement for irrigation. There is also a trend of drawing more water than necessary, which is leading to rapid depletion of the water table. Aligning solar-based generation in the daytime to the agricultural sector demand will lead to more efficient irrigation practices thereby, reducing water consumption. It will also reduce financial and AT&C losses for DISCOMs. This study analyses the feasibility of using existing/proposed ground-mounted solar PV plants (Farmers' Scheme or Taluka level centralised distributed generation in the range of 1-5 MW) to supply the DAFs in Karnataka.

5. Study Design and Methodology

This section elaborates upon the design of the study carried out for this project and the methodology followed to arrive at conclusions and recommendations for using solar-based generation to supply DAFs in Karnataka.

5.1. Phase 1: Selection of Study Area

The study areas cover entire Karnataka (all DISCOMs) where segregation of agricultural feeders have been/will be undertaken. Most DISCOMs have achieved almost 85% of segregation except MESCOM. IP set feeders have been segregated by these DISCOMs to account for agricultural consumption in their annual financial reports. A vast majority of farmers use the supplied power for irrigation. However, due to irregularities in supply timing they keep their IP sets on throughout the day to draw water whenever power is available. This adversely affects both IP sets as well as the distribution network infrastructure of DISCOMs. In this study, the problems faced by DISCOMs – because of free/subsidised power supply for IP sets – are studied and solution in the form of a total system design using solar power generation for agricultural feeders is proposed.

5.2. Phase 2: Inspection Survey and Data Collection

As part of inspection processes across Karnataka, various surveys through site visits, stakeholder discussions and questionnaires were undertaken to obtain information regarding farming patterns, quality of supply in rural areas and irrigation timings.

The data for the current study was collected from DISCOMs and State Load Despatch Centre (SLDC) at the taluka level, KERC and the Energy Department, GoK. DISCOMs have provided data about status of feeder bifurcation, Supervisory Control & Data Acquisition (SCADA) measurements for feeder load details and substation locations, transformer loading, available capacity, number of existing and planned feeders. Solar radiation profiles for specific locations were obtained from National Renewable Energy Laboratory (NREL) databases. Financial statement of DISCOMs, annual amount sanctioned for compensations, cross-subsidy regime and APPC calculation details were taken from annual reports of DISCOMs and KERC tariff orders.

5.3. Phase 3: Technical System Designs for Supplying Solar Power to Feeders

5.3.1. Case 1: Off-Grid PV Plant with Battery Storage

In order to ensure that a dedicated feeder is supplied purely by solar-based generation, one option is to disconnect the specific feeder from the grid – at the substation – and then connect it to a ground-mounted PV plant with storage. This system needs to be designed in such a way that the battery will provide power to the feeder when there is not enough solar radiation or intermittency during times of demand and the PV plant will provide power when there is enough solar radiation. The optimal size of the PV plant and battery storage capacity will depend on the economics of various permutations and combinations. The schematic for such a system design is depicted in Figure 12.

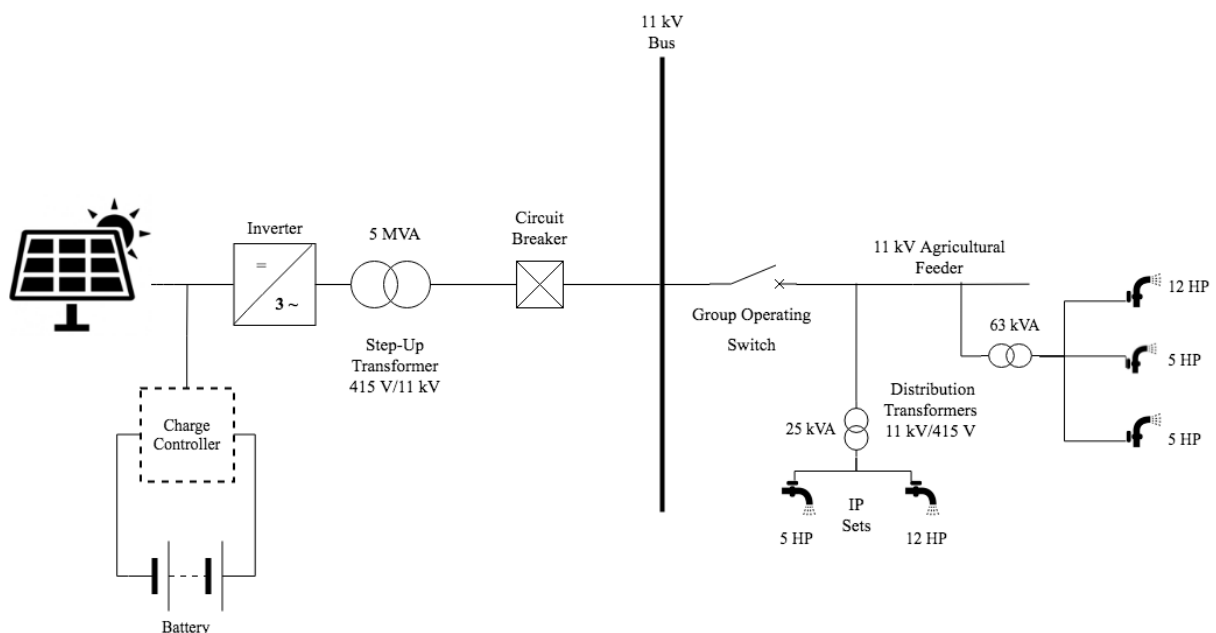

Figure 12: Off-grid PV with battery storage to supply DAF

5.3.2. Case 2: Off-Grid PV Plant with Water Storage

A variation of the previous system design is to replace battery storage with a surface reservoir to store water. Instead of storing electricity in a battery, the scope of this project allows water – which is the end product for irrigation purposes – to be readily available in a surface reservoir. The PV plant needs to be sized in such a way that during times of excess generation, the power can be used to allow IP sets to pump water to a centralised tank on the farmland. When solar radiation is not enough to supply the demand of the agricultural feeder, water from this tank can be used to compensate for the deficit. Farmers need to collaborate with each other in order

for this scheme to work in terms of choosing the optimal size and location of tanks. One component of this system design is the need for a battery which is needed for matching of the PV plant's inverter module. However, unlike the previous configuration, the battery capacity needs to be just enough for allowing the inverter to start operation and does not need to supply the feeders. The expected size of the battery is ~20% of the previous system design's battery size. The schematic for such a system design is depicted in Figure 13.

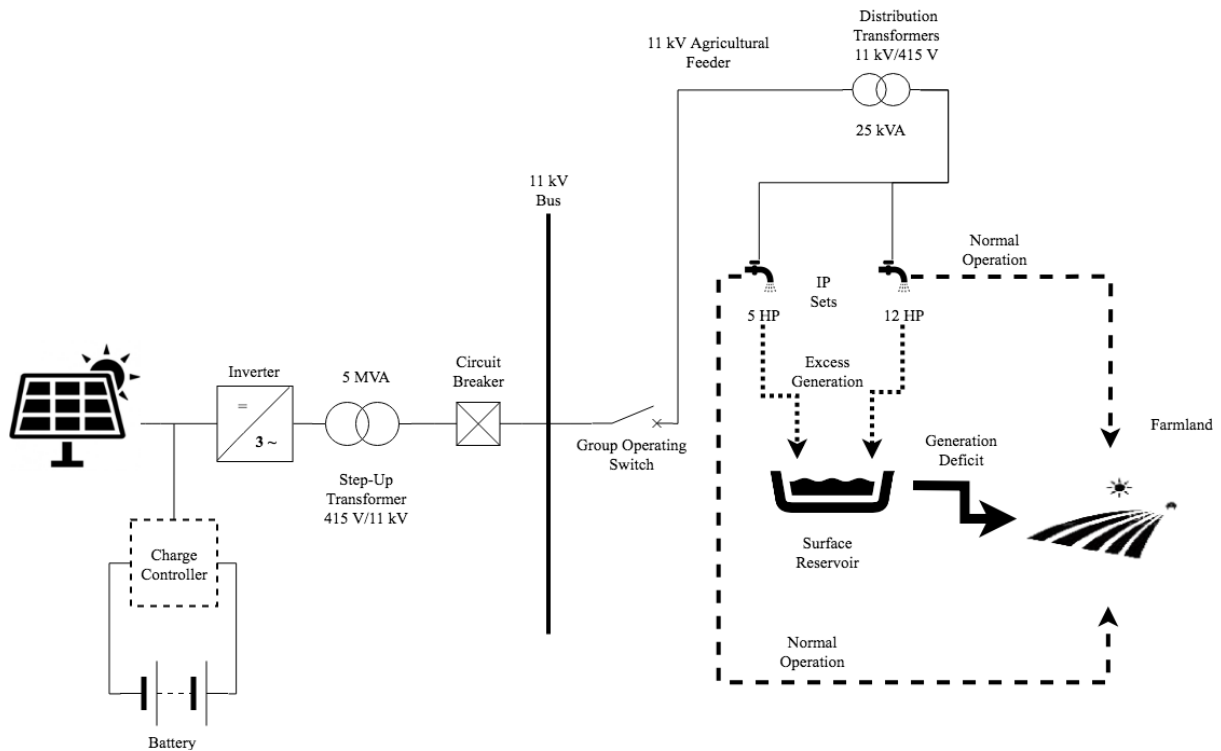

Figure 13: Off-grid PV with surface water reservoir to supply DAF

5.3.3. Case 3: Off-Grid PV Plant with Battery Storage and Scheduling

In places with relatively good rainfall and underground water levels, it is not necessary to irrigate crops every day. This provides the scope to design a system which allows one ground-mounted off-grid PV plant with suitable battery storage capacity to supply two or more DAFs in the same vicinity with a scheduling algorithm. Based on the location and specific geographical/topographical conditions, it is possible to provide power on alternate days to two feeders or every third day to three feeders, etc. The schematic for such a system design is depicted in Figure 14.

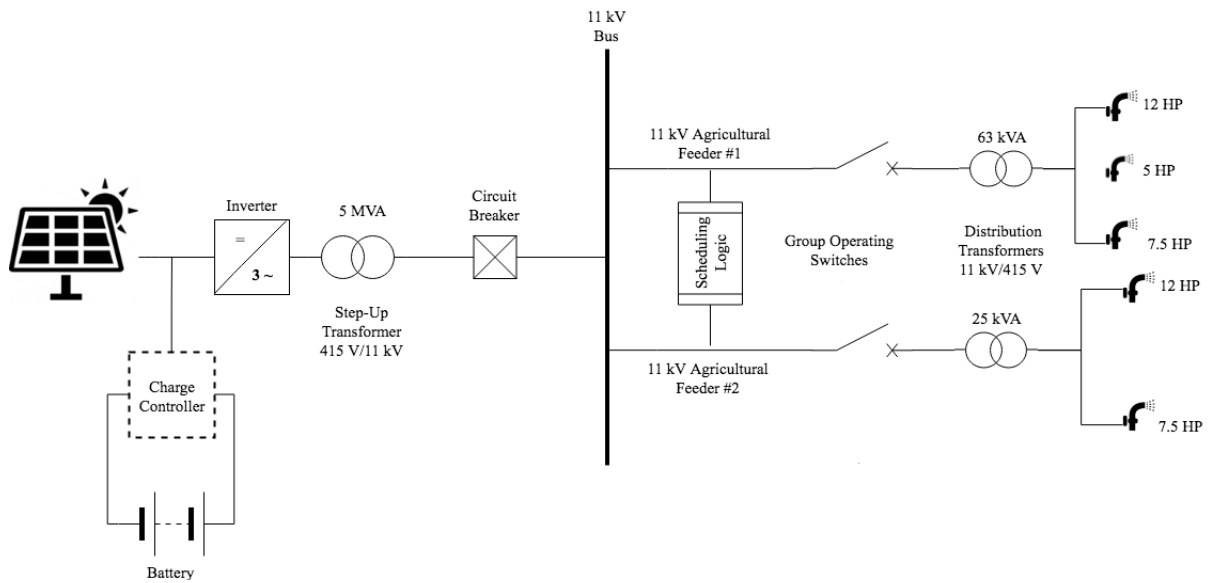

Figure 14: Off-grid solar with battery and scheduling to supply two or more DAFs

5.3.4. Case 4: Grid-Connected PV Plant with One-Way Export to Grid

Another variation of the system design to supply DAFs purely with solar-based generation is to have a ground-mounted PV plant with suitable storage capacity and then connect it with a one-way switch to the distribution grid network. This ensures that in case there is excess power generated because of oversizing of the system (either PV or battery), the electricity does not go to waste but is instead exported to the grid. This switch needs to be operated by a reverse power relay which sends a signal to turn the switch on when the agricultural feeder demand is lesser than the supply from the PV + battery system. This measurement requires two meters to measure power as shown in system design schematic depicted in Figure 15.

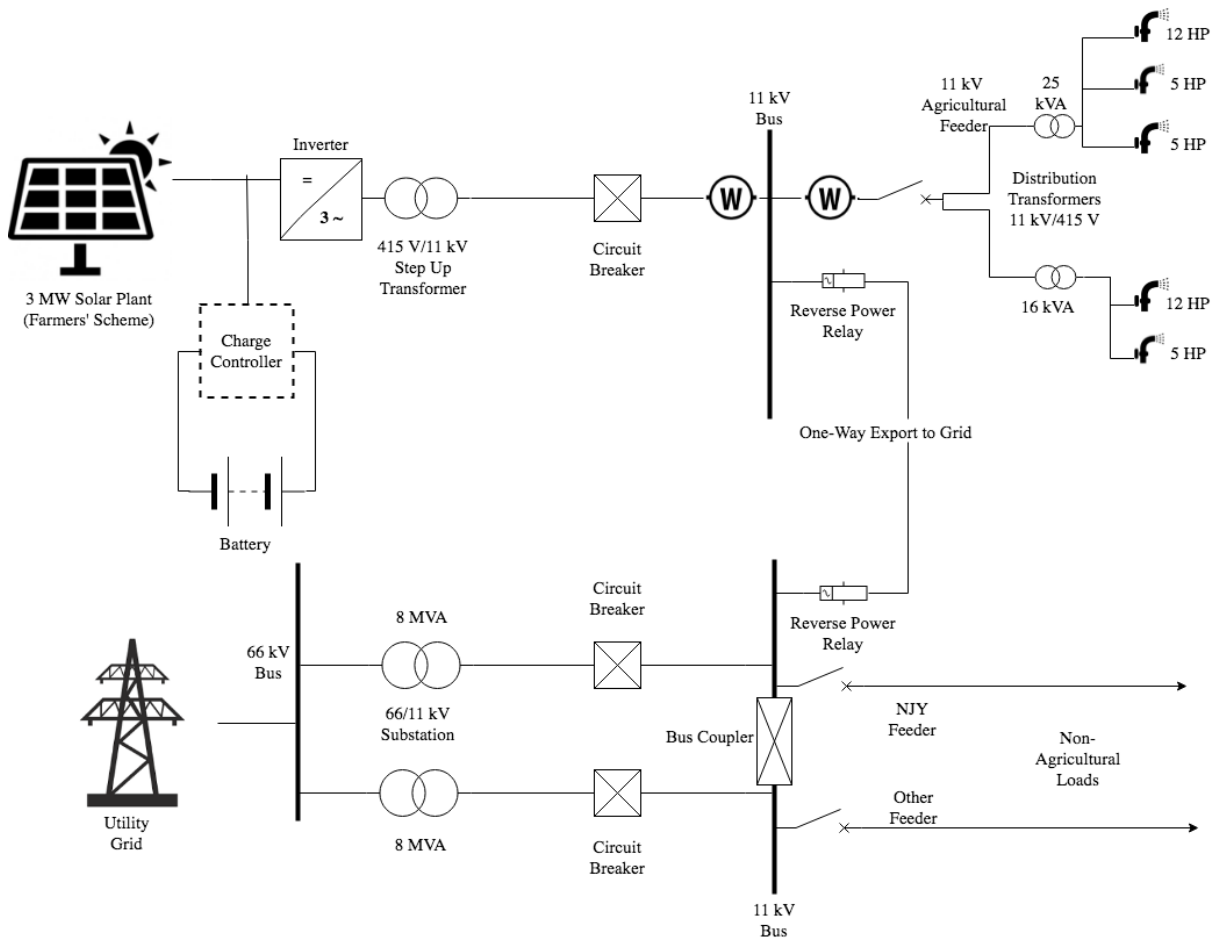

Figure 15: PV with storage to supply DAF and one-way export to grid

5.3.5. Case 5: Grid-Connected PV Plant with Import/Export Option

The most widely used configuration to supply DAFs with solar-based generation is to have a ground-mounted grid-connected PV plant which is connected to the power transformer in the respective substation. The distribution grid acts as the battery in this case and supplies power to the agricultural feeder when solar-based generation is lower than demand and imports power from the PV plant during times of surplus generation.

If the output of the PV plant is at 11 kV, then it is connected to the low voltage side of the substation power transformer and directly to the DAF if required. If the capacity of the PV plant is such that it is not possible to evacuate power at 11 kV levels, then it is connected to the high voltage side of the substation power transformer. The schematics of these system designs are depicted in Figure 16 and Figure 17 respectively.

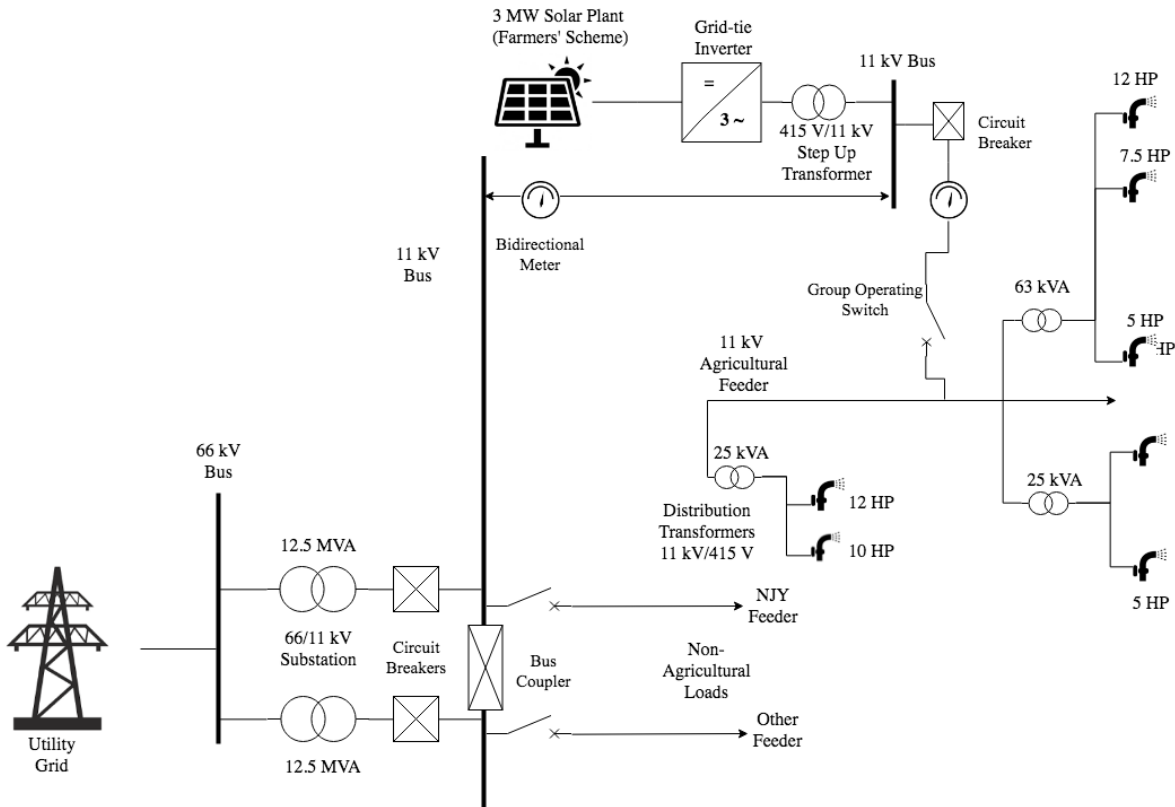

Figure 16: Grid-connected PV plant connected directly to DAF at LT side of substation

In both these cases, accurate designs for switching networks and circuit breakers need to be made so that smooth power flow is obtained and grid-connection regulations are adhered to. This has to be done using simulations in the ETAP software. PVSyst simulations will have to be used to predict the generation from the concerned solar plants.

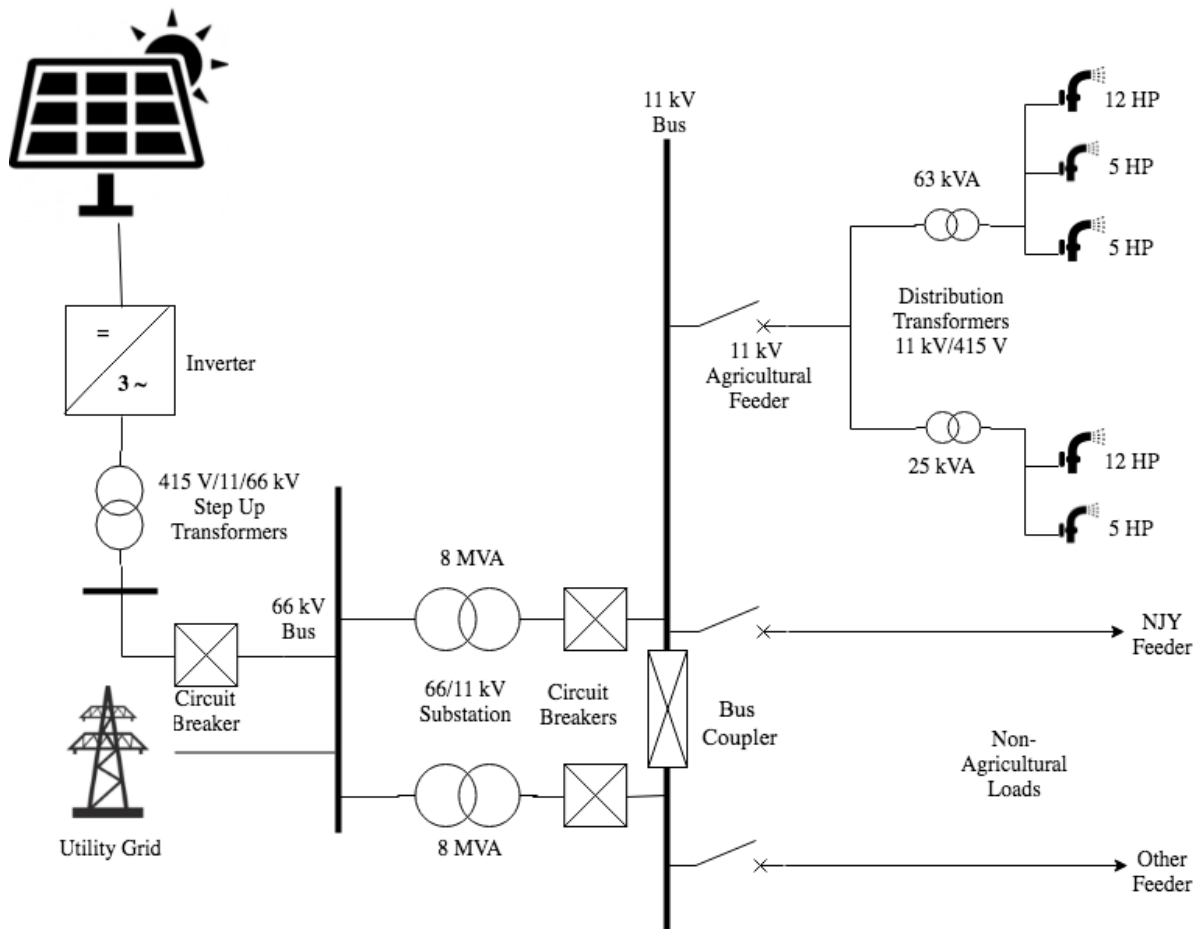

Figure 17: Grid-connected PV plant connected at HT side of substation to supply DAF

5.4. Phase 4: GIS Analysis

Based on the information collected from the Energy Department and DISCOMs at the time of project inception, substations till 66/11 kV levels, power transformers with spare capacities, and existing DAFs in Karnataka have been mapped and geo-referenced. Locations and capacities of existing solar plants along with their distance to the substation from which agricultural feeders emanate have also been mapped. For proposed plants in the future, suitable site selection to supply DAFs has been arrived at using multi-criteria analysis which includes distance to road/rail transport, availability of water bodies, land availability and solar radiation profiles.

This GIS analysis provides geo-referenced results which will allow planners/policy makers to arrive at well informed decisions.

5.5. Phase 5: Policy Recommendations

Based on the findings of the study, each of the aforementioned system designs have been compared from technical, economic and implementation feasibility perspectives. Tools such as Cost-Benefit and Strength-Weakness-Opportunity-Threat (SWOT) analyses have been used to determine the most suitable system designs for supplying DAFs in Karnataka with solar-based generation. Recommendations have been made in the form of a policy framework and an implementable roadmap with business models for developers, revenue models for DISCOMs, and actor networks and roles.

5.6. Phase 6: Integration with DARPAN

The GIS analysis mentioned in the previous section has been visualised on CSTEP's DARPAN platform. In order to make the study more exhaustive, additional policy analyses need to be performed. This includes simulation of the state's electricity infrastructure network with solar, corresponding techno-economics and tariff determination, impact on DISCOMs finance and APPC calculations. CSTEP's DARPAN platform will be used to carry out these aspects of the study in ensuing stages of this project.

The methodology for this project is encapsulated in Figure 18 below.

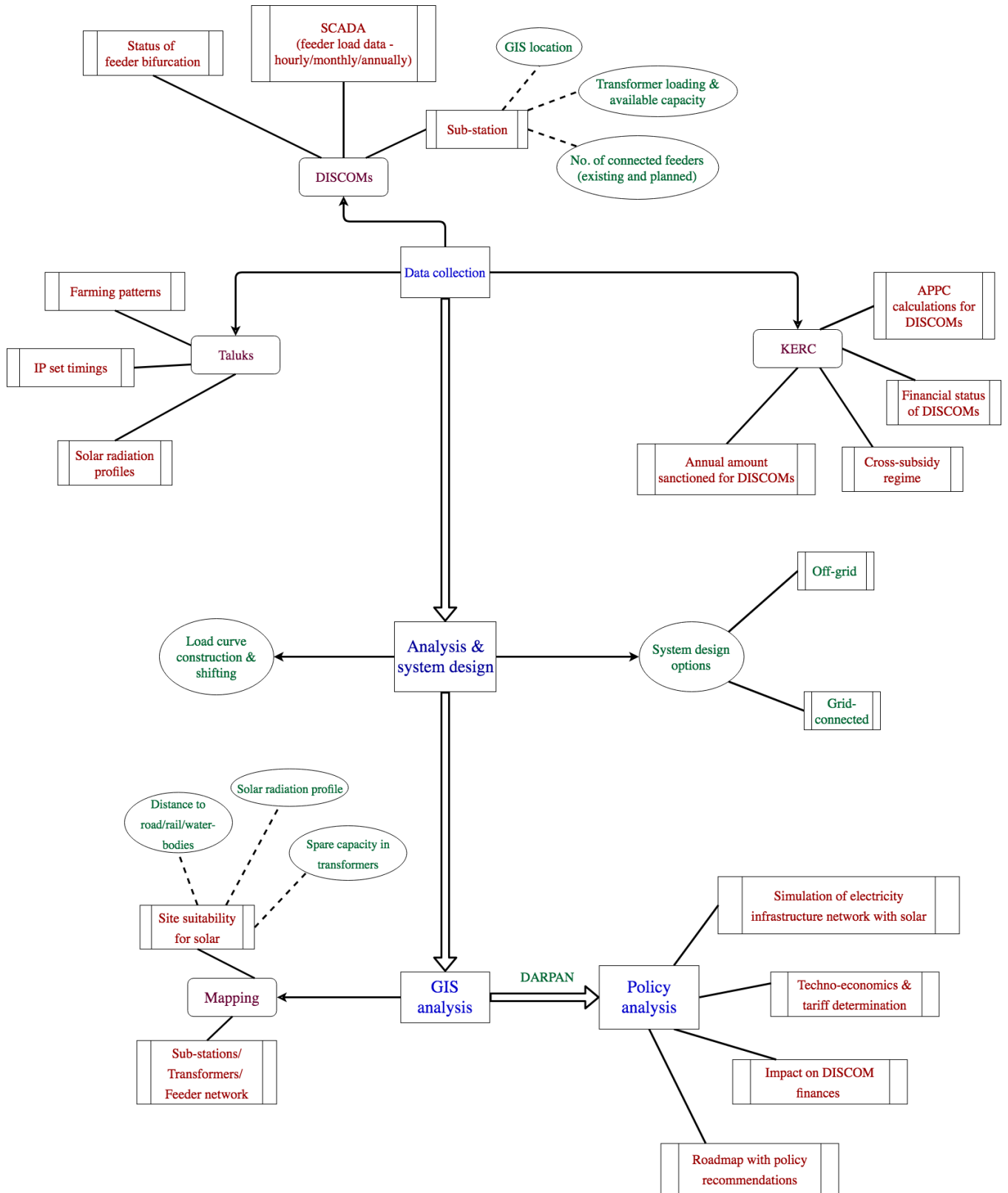

Figure 18: Study methodology to assess feasibility of solar for agricultural feeders

6. Data Collection and Analysis

6.1. Data Collection

The primary data on the status of DISCOM-wise feeder bifurcation was collected from the Energy Department. Further details for the study such as substation, power transformers (PTs) and feeder details were obtained from KPTCL and DISCOMs. The data was received in formats mentioned in the following subsections.

6.1.1. Substation Details

The data formats for substations and feeders are shown in Table 2 and Table 3 respectively.

Table 2: Format for substation-level data

DISCOM	Name of S/S	Voltage class (kV)	No. of PTs	PT capacity (MVA)	Max loading of PTs (MW)	Normal loading of PTs (MW)	Available PT capacity (MW)	No. of 11 kV feeders
--------	-------------	--------------------	------------	-------------------	-------------------------	----------------------------	----------------------------	----------------------

Table 3: Format for feeder-level data

DISCOM	Name of S/S	Name of 11 kV feeder	Type (agri/non-agri)	Type of conductor	Length of feeder	Connected load in kW	No. of IP sets in feeder	Average daily energy sent out in kWh
--------	-------------	----------------------	----------------------	-------------------	------------------	----------------------	--------------------------	--------------------------------------

6.1.2. Existing Solar Plant Details

Details of existing solar plants were collected from Karnataka Renewable Energy Development Limited (KREDL) and SLDC SCADA section. The format for this data is shown in Table 4.

Table 4: Format for solar plant details

Name of IPP	Evacuation voltage (kV)	Installed capacity (MW)	Name of connected S/S	Location co-ordinates	Commissioned date
-------------	-------------------------	-------------------------	-----------------------	-----------------------	-------------------

6.1.3. Load Curve Details

Four substations in each of the five DISCOMs (excluding MESCOM) were chosen for analysis. These substations are located in various locations covering the state of Karnataka and are representative of all substations in the state. Each of these substations have at least one DAF emanating out of the LT side of the respective power transformer making this study exhaustive in its approach in terms of modelling solar PV plants with DAFs in Karnataka. Minute-wise data for the whole year (8,760 hours) of the loading on each of these feeders (both agri/non-agri) were collected from the SLDC SCADA section to construct the annual load curve of these feeders.

6.2. Analysis

Based on the aforementioned collected data, analyses have been performed to estimate the demand on each feeder and shift the demand to the day when solar-based generation is available. This demand has then been used to determine the capacity of the PV plant and associated storage if required. The system designs have then been compared to evaluate the most suitable one in terms of technical and economic viability. These findings have then been mapped on the DARPAN platform for easier visualisation. More details are furnished in the following subsections.

6.2.1. Construction & Shifting of Load Curve

In order to identify the DAFs among the other feeders entering and emanating from the substation, the SCADA details have been analysed. A sample case of the Banangadi substation is shown in Table 5. The incoming 66 kV feeder (F1-Huygonahally) supplies 45,358 kWh to the HT side of the substation on 1st January, 2017 with a peak of 4.39 MW at 11:46 AM and a downtime of 4 hours and 45 minutes. There are two power transformers in the substation. However, only one is integrated with SCADA and delivers 31,292 kWh to the LT side, with a peak load of 3.42 MW at 11:22 AM with no downtime.

There are four outgoing 11 kV feeders from this transformer of which F4-NJY is the non-agricultural feeder providing nearly 24 hours of supply whereas F1-F3 are the DAFs receiving around 7 hours of supply. The data shows that the peak in each of these three agricultural feeders occur at different times of the day which showcases the fact that farmers today do not

have a fixed time for switching on their IP sets. For the sake of illustration, F2-Malligere feeder has been chosen for load curve construction and shifting in this section. The actual load curve has been constructed by taking the minute-wise data on 1st January, 2017 for this feeder and the hourly peak has been considered to be the reference load for each hour. This actual load curve is depicted in Figure 19 which shows that supply is staggered in two phases – 4 hours during the daytime and 3 hours at night.

Table 5: Sample SCADA data of Banangadi substation

Station BANANGADI_66							1-Jan-17
Feeder No.	Feeder name	Supply Duration Hrs:Min:Sec			Peak Load MW		Energy delivered - KWh
		3 ph	Single ph	No supply	MW	Time	
IN F1	F1-HUYGONAHALLY			4:45:00	4.39	11:46 AM	45358
IN F2							
IN F3							
IN F4							
IN F5							
IN F6							
IN F7							
TR 1	T1-66/11-TR1	24:00:00			3.42	11:22 AM	31292
TR 2							
TR 3							
TR 4							
TR 5							
TR 6							
F1	F1-BANNANGADI	6:59:00		17:01:00	1.59	11:46 AM	-8224
F2	F2-MALLIGERE	6:59:00		17:01:00	1.57	11:01 AM	-7820
F3	F3-GIRIYARAHALLI	7:02:00		16:58:00	1.77	3:11 PM	-8694
F4	F4-NJY	23:26:00		0:34:00	0.62	7:26 PM	-6160
F5							
F6							
F7							

Actual load profile of F2-Malligere

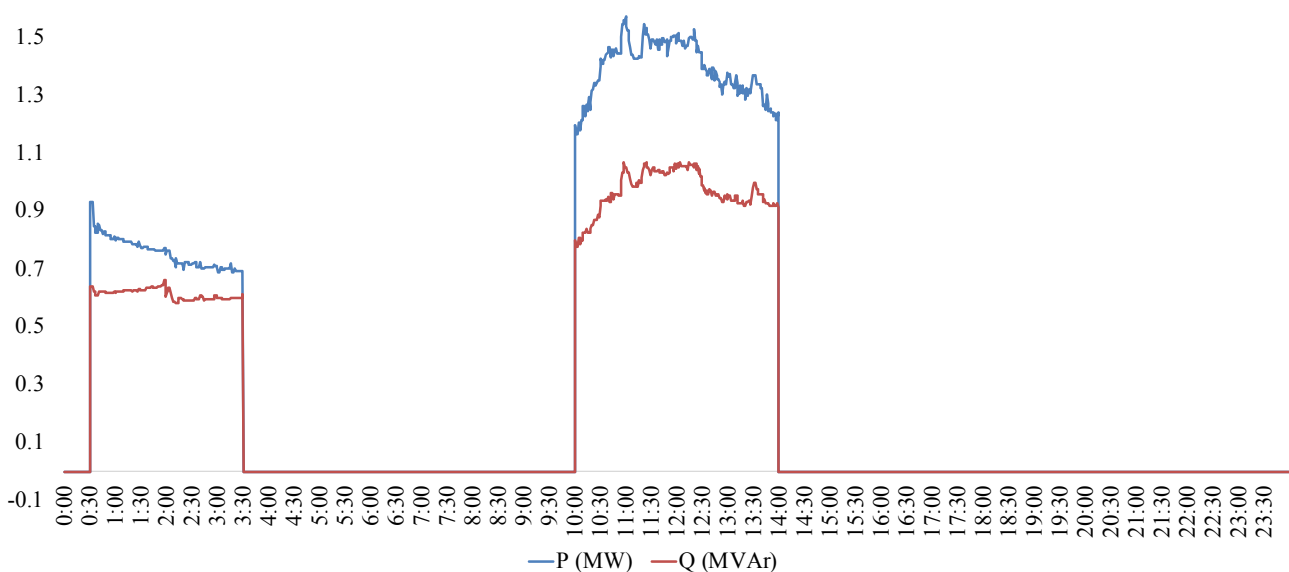

Figure 19: Actual load curve of F2-Malligere DAF on 1st January, 2017

As mentioned in the Objectives section, the purpose of this study is to design a system which allows solar-based generation to supply the demand of DAFs. Hence, it is necessary to shift the actual load curve to the daytime for seven hours when there is solar radiation available for electricity generation. This will also allow farmers to have access to uninterrupted power supply during the day which is what they prefer because this is usually the time when they work in the fields. In order to shift and reconstruct the actual load curve, the load profile for each hour was observed to determine the load factor – the ratio between average load to maximum load in an hour. This was then used to project the demand for the 7 hours in the daytime. Keeping in mind that the demand is likely to increase in the future and the past trends, a 2% escalation per annum has been assumed which is capped after five years. The reconstructed load curve of F2-Malligere feeder for 1st Jan, 2017 is shown in Figure 20 and the projected annual load curve (8,760 hours) for the future is shown in Figure 21.

F-2 Malligere (shifted load curve for a day - 1st January 2017)

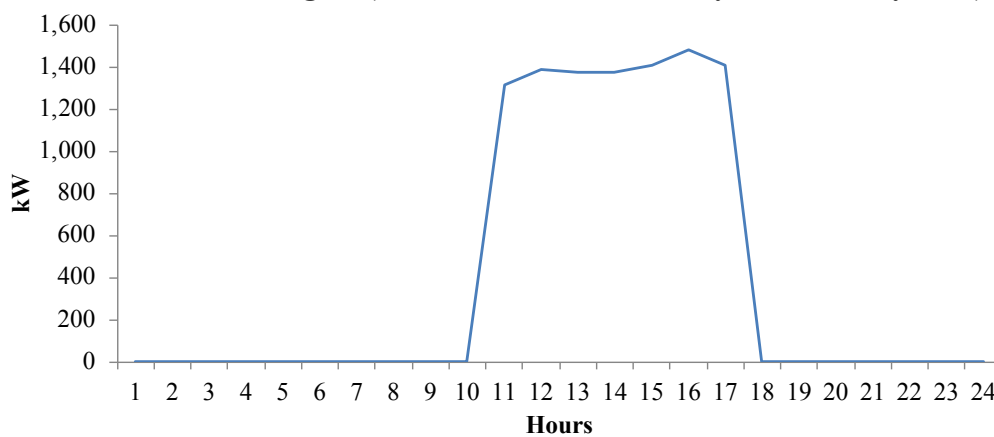

Figure 20: Representative reconstructed load curve for a DAF in Karnataka

F2 - Malligere (reconstructed annual load curve for the future)

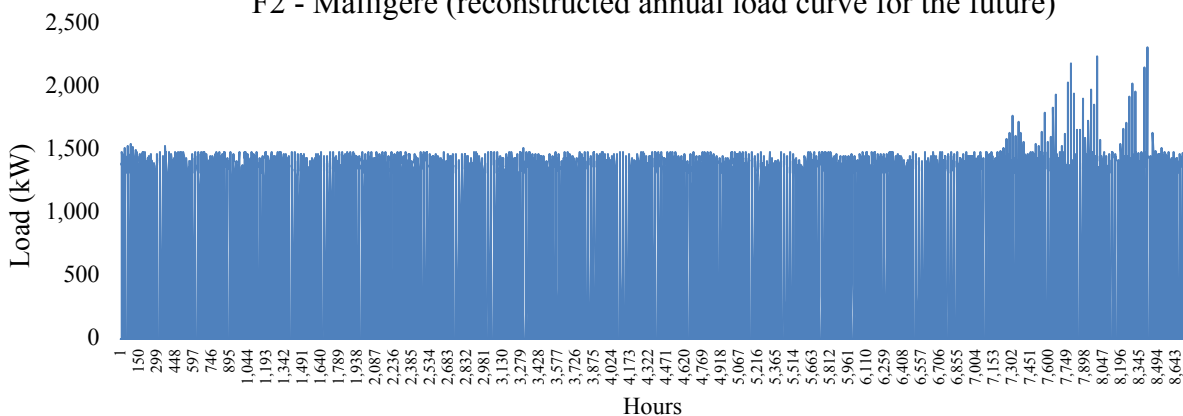

Figure 21: Representative annual load curve for a DAF in Karnataka

6.2.2. System Design

The projected annual load curve for a DAF was taken as the reference. The required solar PV capacity along with storage (in case of grid-connected) or with grid as the backup was calculated in such a way that this reference demand is met at every hour of the year. For the **off-grid PV design options with battery storage**, the HOMER software tool was used in the micro-grid modelling configuration. In this configuration for a single feeder or two feeders with rostering, the minimum state of charge of the battery has been fixed at 30%. Once the optimal sizes of the PV plant and battery storage were determined by HOMER, techno-economics along with Levelised Cost of Electricity (LCOE) calculations were performed separately. A snapshot of the simulation in HOMER for F2-Malligere feeder with PV and battery storage is shown in Figure 22.

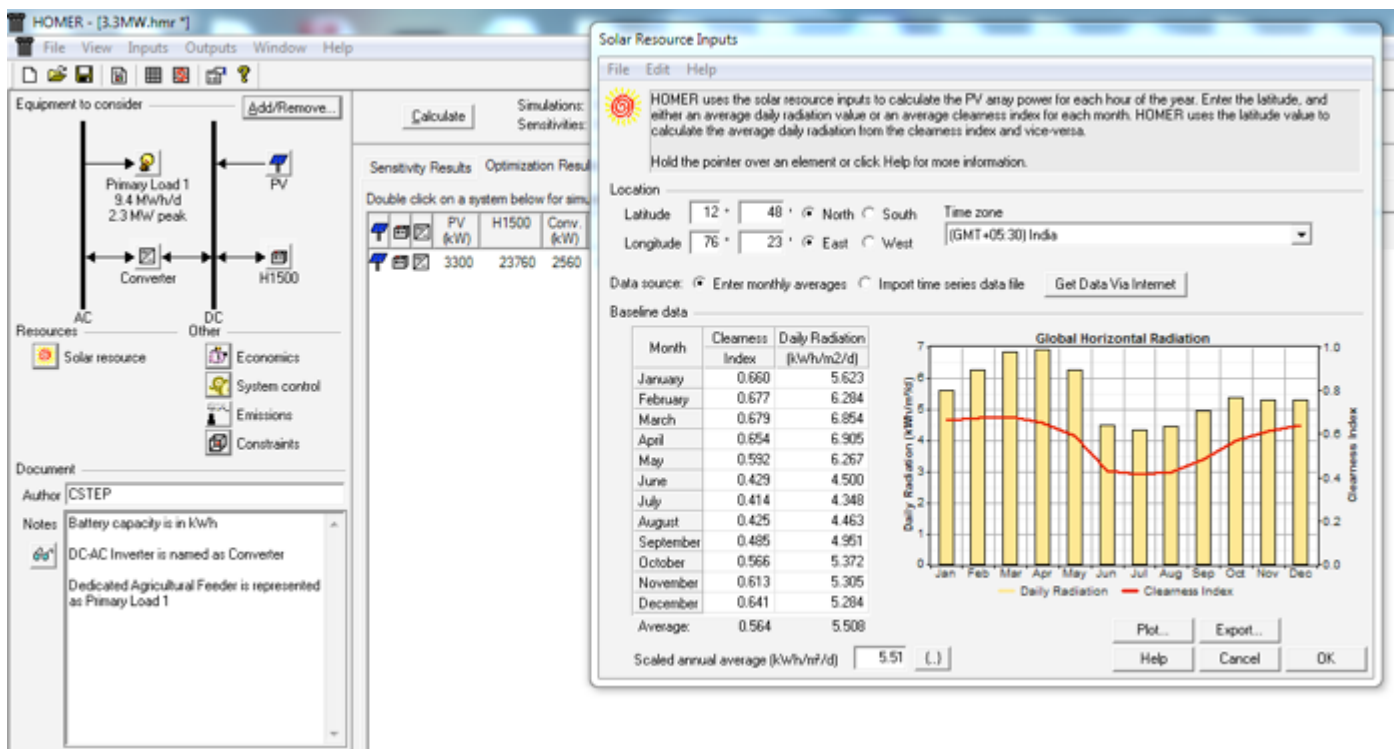

Figure 22: HOMER simulations for off-grid PV with battery storage

For the **off-grid PV design with water storage in a surface reservoir**, the HOMER configuration of PV + battery was taken as reference. The maximum discharge from the battery (in kWh) on one day was chosen to be the base case for replacing battery with water storage. The amount of water to be stored was calculated by taking a 5 HP IP set with 240 m as water table depth and the amount of water pumped by the electricity supplied from the battery alone

was determined. Taking losses from the battery into account, the amount of additional energy (in kWh) required to pump the desired amount of water for storage was calculated. This energy was then matched with solar-based generation over 7 hours in a day in the particular location to calculate the additional solar capacity (in MW) required to supply the demand on top of the PV capacity designed in HOMER.

For the grid-connected PV designs, the peak load of the project annual load curve was taken as reference. After considering standard losses, the required capacity of the PV plant was determined. This plant was then simulated in the PVSyst software to obtain the annual generation profile. This generation profile was then used for reference in the ETAP software simulations where the DAF was modelled taking length of feeder and number of IP sets into consideration. This led to the determination of the total number of either the PV plant or the grid supplying the DAF. The representative cases for F2-Malligere feeder are depicted in Figure 23 and Figure 24 respectively.

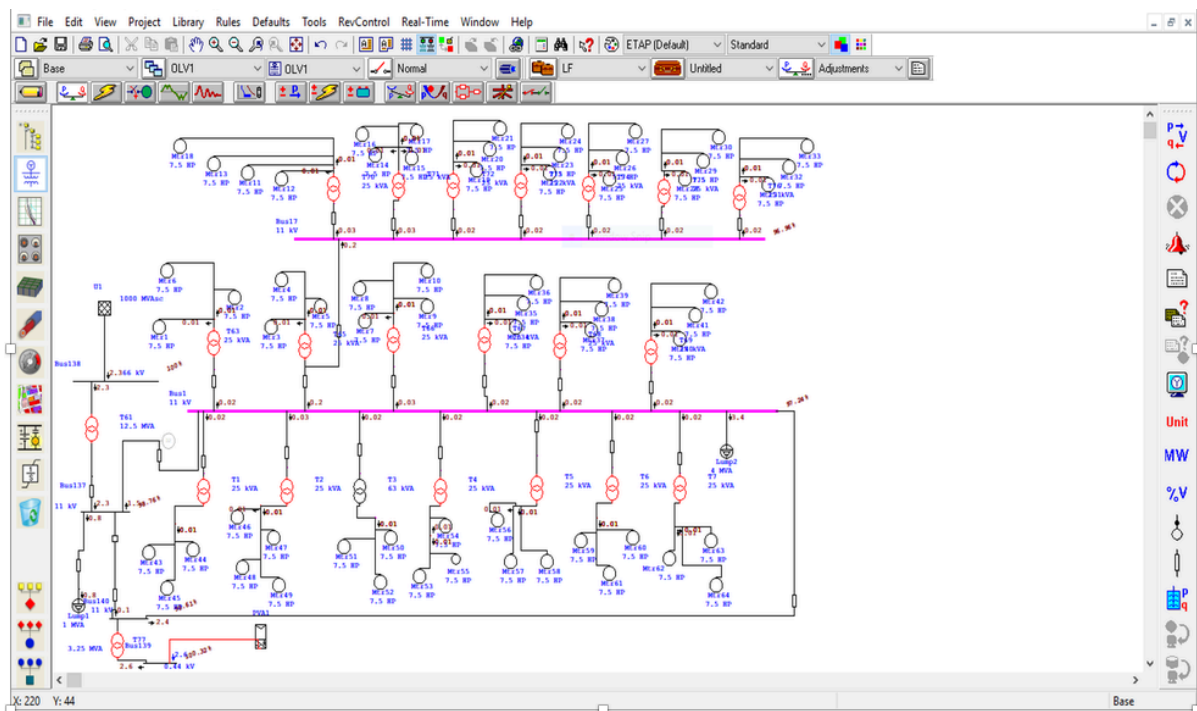

Figure 23: ETAP simulation for grid-connected PV for F2-Malligere feeder

Grid-Connected System: Main results

Project : Bannangadi
Simulation variant : New simulation variant

Main system parameters	System type	Grid-Connected	
PV Field Orientation	tilt	28°	azimuth 0°
PV modules	Model	TSM-250 PDG5	Pnom 250 Wp
PV Array	Nb. of modules	12006	Pnom total 3002 kWp
Inverter	Model	Sinvert PVS1000 US	Pnom 1000 kW ac
Inverter pack	Nb. of units	3.0	Pnom total 3000 kW ac
User's needs	Unlimited load (grid)		

Main simulation results
 System Production **Produced Energy 5207 MWh/year** Specific prod. 1735 kWh/kWp/year
 Performance Ratio PR **81.30 %**

Normalized productions (per installed kWp): Nominal power 3002 kWp

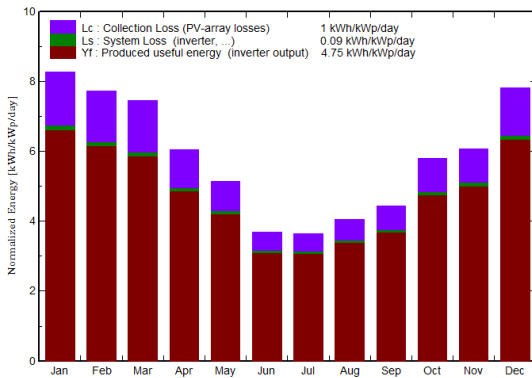

Performance Ratio PR

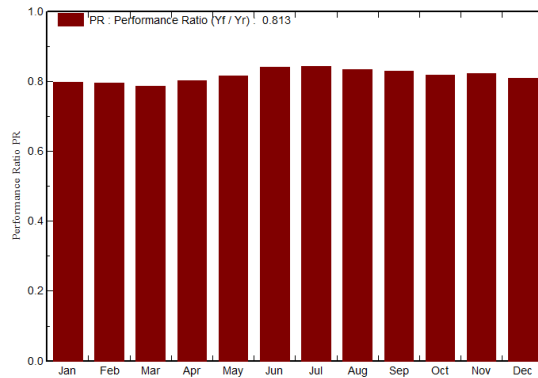

New simulation variant Balances and main results

	GlobHor	DiffHor	T Amb	GlobInc	GlobEff	EArray	E_Grid	PR
	kWh/m ²	kWh/m ²	°C	kWh/m ²	kWh/m ²	MWh	MWh	
January	201.6	26.49	22.04	256.8	251.7	628.5	616.1	0.799
February	188.1	38.25	24.17	216.8	212.0	528.0	517.7	0.796
March	224.7	48.67	26.53	231.3	225.5	557.8	547.0	0.788
April	200.2	69.95	27.22	181.9	175.8	446.9	438.3	0.803
May	191.1	77.60	26.60	159.8	153.4	399.5	391.9	0.817
June	132.5	78.63	24.25	110.7	106.0	285.0	279.5	0.841
July	133.1	83.02	23.86	112.9	108.1	291.8	286.1	0.845
August	140.8	71.23	23.50	125.6	121.1	321.5	315.1	0.836
September	138.1	68.56	23.55	133.1	128.7	338.2	331.6	0.830
October	166.7	70.00	23.49	179.7	174.9	450.9	442.0	0.819
November	155.5	61.80	22.12	182.6	178.3	460.8	451.8	0.824
December	187.4	30.73	21.32	242.7	238.3	602.0	590.0	0.810
Year	2059.7	724.92	24.05	2134.0	2073.8	5311.0	5207.1	0.813

Legends: GlobHor Horizontal global irradiation GlobEff Effective Global, corr. for IAM and shadings
 DiffHor Horizontal diffuse irradiation EArray Effective energy at the output of the array
 T Amb Ambient Temperature E_Grid Energy injected into grid
 GlobInc Global incident in coll. plane PR Performance Ratio

Figure 24: PVSyst report for 3 MW PV plant for F2-Malligere feeder

6.2.3. Visualisation Platform

Based on the results of the comparisons of the system designs, the most suitable one has been recommended for widespread adoption in Karnataka to supply DAFs in the state with solar-based generation. As a part of this project, based on the available data, 66/11 kV substations have been mapped and georeferenced along with the DAFs emanating from the LT side of the substations. CSTEP’s DARPAN platform has been used to also select the suitable sites for PV plants to supply these feeders. Site suitability has been determined by distance to substation/roads/railway network, land use/land classification (LULC) data and solar radiation profiles in the area along with spare transformer capacity in the respective substations. This visualisation platform depicted in Figure 25 will enable policy makers, developers and DISCOMs to effectively plan the implementation of solar PV plants to supply DAFs in the near future.

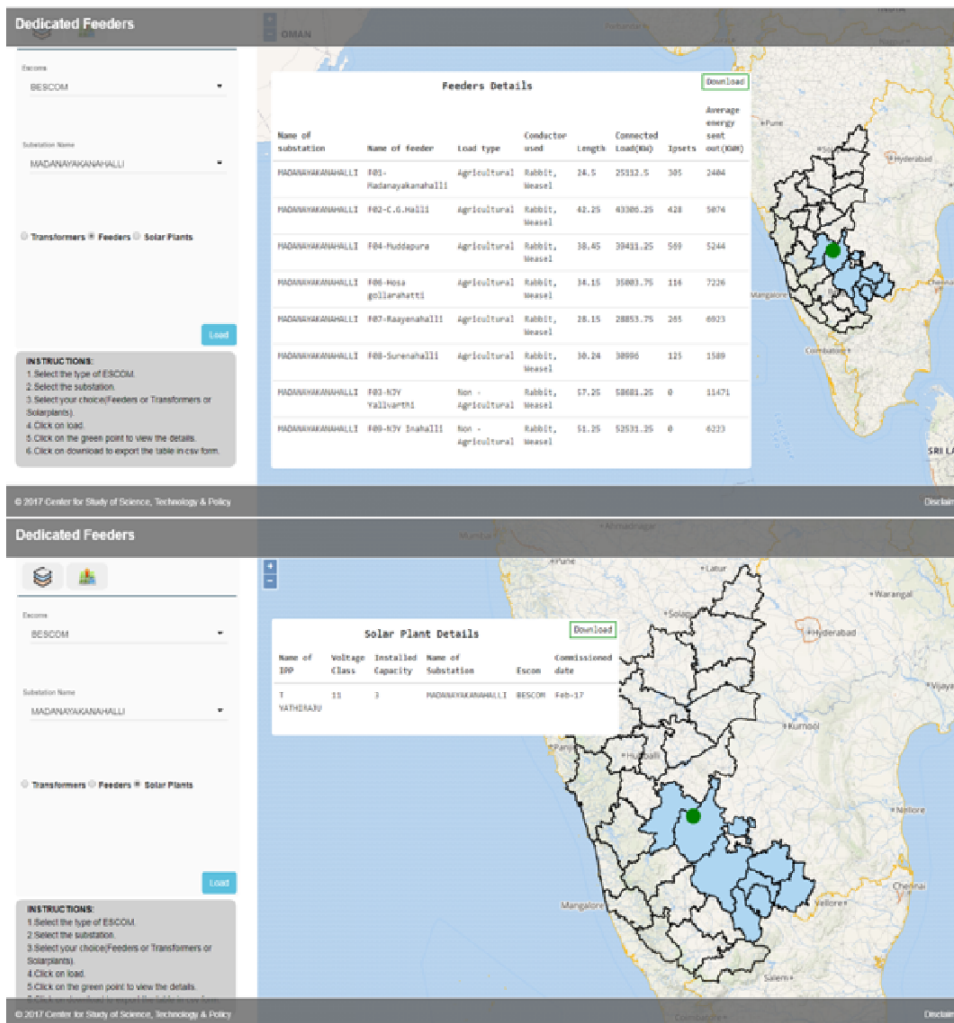

Figure 25: DARPAN visualisation platform for DAFs in Karnataka with PV plants

7. Findings and Discussion

The initial request from the Energy Department of GoK was to develop a system design which ensures that the DAFs are supplied only with solar-based generation from PV plants. The following system designs were considered for analysis:

- Off-grid PV with battery storage
- Off-grid PV with battery storage and scheduling
- Off-grid PV with water storage
- Grid-connected PV with storage and one-way export

The representative case shown for consideration is the Banangadi substation (part of CESC network) in the Pandavapura taluka in Mandya district. The details of the incoming and outgoing feeders are presented in Table 5. The capacities and techno-economics of each system design are summarised in Table 6.

Table 6: Economics of system designs to supply DAFs in Banangadi substation only with solar-based generation

<i>Off-grid PV with battery storage</i>								<i>Grid-connected with one-way export</i>
PV (MW)	Pb-Acid Battery (MWh)	PV Annual Generation (MU)	Annual Load (MU)	Excess	Excess (MU)	Hours of excess	LCOE (INR /kWh)	LCOE (INR /kWh)
3.3	71.28	5.53	3.43	29.3%	1.61	2,030	23.09	16.8
6.5	21.6	10.9		64.7%	7.0	3,606	13.08	7.6
<i>Off-grid PV with battery storage and scheduling</i>								<i>Grid-connected with one-way export</i>
3.2	94.3	5.3	3.39	26.7%	1.41	1,862	29.5	21.6
3.7	55.1	6.1		37%	2.26	2,433	19.3	12.2
6	32.4	9.9		61.6%	6.12	3,584	15.6	7.4
9	21.6	14.9		74.5%	11.1	3,979	15.9	6.8
<i>Off-grid PV with water storage</i>								<i>Grid-connected with one-way export</i>
PV (MW)	Water Storage (litres)	PV Annual Generation (MU)	Annual Load (MU)	Excess	Excess (MU)	Hours of excess	LCOE (INR /kWh)	LCOE (INR /kWh)
13	4,43,650	21.6	12.3	43%	8.01	3,623	11.5	7.3

7.1. Off-Grid PV Plant with Battery Storage

It can be seen from Figure 21 that although the projected annual load curve for a DAF remains flat for a majority of the year, there are certain days when spikes are 60% higher than the normal load throughout the year. These anomalies in the projected annual load curve arise due to the dependency of agricultural demand on seasonal variations and local crop requirements. During these times of high demand, farmers use more than one IP set or the same IP set for longer hours; either to satisfy the water needs for a growing crop or to compensate for lack of precipitation. These spikes in demand lead to oversized off-grid system designs with either a high battery storage capacity or a larger PV plant (Figure 12). These results are represented by the models created in HOMER for F2-Malligere and are shown in Table 6.

The oversizing of system components means that for a major portion of the year when the load curve is flat, there is excess generation which remains unutilised. This leads to LCOEs which are much higher than the APPC of Karnataka DISCOMs. Since battery costs today are prohibitively high for large scale systems, the results show that oversizing the PV plant instead of the battery reduces the LCOE by nearly 45%. Even with an oversized PV plant, the LCOE of this system is more than 3.5 times that of the APPC of DISCOMs in Karnataka. This makes pure off-grid with battery storage an **economically unviable** solution to supply DAFs in Karnataka, in spite of ensuring that these feeders can technically be fed only with solar-based generation.

In terms of technical issues, off-grid protection schemes need to be used during times of fault in the line which will also reduce generation and thereby developer revenues. Over Current Relays (OCRs) & Earth Fault Relays (EFRs) protection for the feeder is to be provided at the PV plant side with a breaker and the PV plant staff have to close the breaker in case of any faults. To attend any line fault, “line clear” needs to be taken from the PV plant end. There needs to be a consensus regarding how BESCO staff can take “line clear” from IPP staff (as it is not grid-connected). This is to safeguard maintenance personnel. There is also a possibility of the developer losing revenue if there is no load on the feeder and the battery is in fully charged condition.

7.2. Off-Grid PV Plant with Battery Storage and Scheduling

Agriculturalists and researchers have shown that very few crops actually need water every day for growth. The need for irrigation arises only when the soil is in the process of drying up, which in the most arid regions of Karnataka happens on alternate days. Hence, there is a possibility of using the same solar plant to supply two or more DAFs based on the geographical location (Figure 14). The plant can supply power to these feeders on a scheduled basis with prior information being made available to the farmers. This can reduce the capital costs of the system and LCOE.

This is represented in the Banangadi substation by combining the loads of F2-Malligere and F3-Giriyarahalli DAFs and supplying them on alternate days using one solar PV plant with battery storage. The HOMER simulations for this configuration (Table 6) show that the battery capacity requirements are higher than the previous configuration, where a single solar PV plant with battery storage supplied only one DAF. The various combinations of either increasing PV capacity or storage capacity to meet the spikes in annual demand as mentioned in the previous section still lead to excess generation which cannot be used. This increases the LCOE and even the most optimal system design in terms of techno-economics is more than 4 times than the APPCs of DISCOMs in Karnataka. Not only is this design **economically unviable** for supplying solar-based generation to DAFs in Karnataka, there is also a possibility of **farmers being unwilling** to co-operate based on a scheduling algorithm to receive power. Opposition to change can create barriers for adoption of such a system design and this creates a **political issue**. The aforementioned technical issues for Off-Grid PV Plant with Battery Storage apply here as well.

7.3. Off-Grid PV Plant with Water Storage

Since costs of MW level battery storage are still prohibitively high, water can be stored instead in surface reservoirs by creating additional solar PV capacity. Considering the case for F2-Malligere (Table 6), the spikes in demand in some days of the year mean that the size of the reservoir has to be large enough to hold the required amount of water during those days (Figure 13). However, just like the previous two system designs of off-grid PV with battery storage, most of the days in the year will not require the maximum amount of water that can be stored in the reservoir. This translates to an oversized PV plant with more than 40% excess generation which goes to waste. The LCOE of such a system design – including cost of new pumps to

supply the reservoir and the cost of building the reservoir itself – is around 3 times more than the APPC of DISCOMs in Karnataka. Hence this option of replacing large-scale battery storage with water storage is also **economically unviable** to supply solar-based generation to DAFs in Karnataka. Moreover, the system also needs a smaller battery for matching of the PV plant inverter module for plant operation.

Apart from the economic issues of such a scheme, there are other constraints as well. In order to achieve economies of scale, it is essential to have co-operation among farmers to have a single reservoir catering to the needs of a group of farmers. This system can work well in places with river and canal-based irrigation. Here, lift irrigation MW level pumps can be used to fill up the reservoir from the river and then the required water is discharged to the fields, when required, through the canal network. Such areas in Karnataka are present only in the coastal regions and in Bagalakote, Belgaum, Haveri, Shivamogga and Mandya¹. Also, construction and maintenance of canals and sub-canals will be an issue and expensive metal pipes could be used. Hence, this concept is **selectively technically viable and cannot be used for widespread adoption** in Karnataka. The aforementioned technical issues for Off-Grid PV Plant with Battery Storage apply here as well.

7.4. Grid-Connected PV Plant with Storage and One-Way Export

In all the previous three system designs, a commonality is the economic unviability because of excess generation arising out of oversized systems needed to meet the seasonal spikes in the projected annual load curves. Off-grid system designs do not allow this excess generation to be utilised or compensated monetarily. This impediment could be resolved through the design of a system which allows for one-way export of the aforementioned excess generation to the grid through a reverse power relay-based grid-interaction protocol. The reverse power relays need to have Intelligent Electronic Devices (IEDs), since the IEDs have data storage capability, which will help for further analysis. This design is a hybrid between off-grid and grid-connected solar plant wherein there is no import from the grid ensuring that only solar-based generation is used to supply DAFs; the excess generation is sent to the grid, thereby earning revenue for the project developer (Figure 15). Table 6 shows that the LCOE of such a system design for F2-Malligere (and F3-Giriyarahalli in case of the scheduling system design) is around double that of the APPC of DISCOMs which **slightly increases the economic**

¹ Irrigation in Karnataka - <http://knnlindia.com/pdf/Annual%20Report%202017%20English%20with%20Photos.pdf>

viability. However, the **technical viability of such a system design is dependent** on there being a product in the market which has the logic in the power electronics of the relay to allow for only one-way export to the grid during times of excess generation. Currently, these reverse power relays are only present in high voltage transmission systems. This scheme is akin to the Surya Raitha scheme of GoK which enables farmers to use solar IP sets and export the excess generation to the grid and the technical similarities need to be explored for widespread adoption of this system design. Another envisaged issue with this design is the possibility of rapid switching of relays and numerous dynamics that may arise because of the intermittency aspect of solar radiation. It will be difficult to smoothly operate switching protocols between the grid and the battery.

These four system designs show that using only solar-based generation to supply DAFs in Karnataka is not economically viable at the moment. Hence, there is a need to innovate in grid-connected PV design options with the feature of accurate accounting of consumption of DAFs from the grid and respective solar PV plants. The following subsections elaborate upon such system designs developed in this study.

7.5. Grid-Connected PV Plant Connected Directly to DAF at LT Side of Substation

This proposed system design involves disconnecting the existing DAF from the LT side of the substation and connecting it directly to the PV plant (Figure 16). Meters will have to be installed on the solar generation side and on both sections of the DAF to record the amount of power being supplied by the PV plant, consumed by both sections of the DAF and imported from or exported to the grid. Based on the ETAP simulations (Figure 23) of the F2-Malligere feeder with the existing 3 MW Farmers' Scheme PV plant, it can be seen that the grid supplied only ~17% of the projected annual demand of the DAF and the rest is supplied by solar-based generation. Also, the excess generation from the solar plant can be directly exported to the grid thereby protecting the interests of the developer. The LCOE of this system design (inclusive of costs of disconnection and reconnection of DAF and other additional system components) is only around 12% more than the APPC of DISCOMs (Table 7) making it **economically viable** to supply DAFs in Karnataka with solar-based generation.

There are some **technical constraints** with this system design. This configuration has not been implemented anywhere in the state or country so far. There is a need to study two ground-level pilots by physically disconnecting some existing DAFs from substation and connecting them

directly to commissioned solar PV plants in the vicinity. DAFs are prone to faults and line clearances because of the inherent nature of the lines going through fields and dense shrubbery. Data collected from the field shows that, on an average, each DAF suffers from around 15 outages per month with a downtime of nearly 10 hours. Solar plant developers might resist the implementation of such a system design because there is a threat of generation and revenue loss when the DAF is not operational. In these times, the switchover to supply directly to the grid has to happen fast and this needs careful monitoring of the DAF by the respective DISCOMs. The pilots will help in gathering information about these issues and resolving them before a widespread rollout of such a scheme.

Two sources are made available near the PV plant. Hence, to avoid any mishaps, it should be made mandated that both the existing evacuation line and the DAF sources are from the same bank of the same substation and phasing out of these two sources is to be done and also to be connected together during pre-commissioning tests.

Table 7: Economics of system designs to supply DAFs in Banangadi substation with grid-connected PV plants

PV (MW)	PV Annual Generation (MU)	Annual Load (MU)	Import from Grid (MU)	Hours of Import	Export to Grid (MU)	Hours of Export	LCOE (INR /kWh)
<i>PV plant connected directly to DAF at LT side of substation</i>							
3	5.16	3.43	0.57	990	2.27	3,136	4.2
<i>PV plant connected directly to HT side of substation</i>							
3	5.16	3.43	0.59	993	2.3	3,145	4.03

7.6. Grid-Connected PV Plant Connected at HT Side of Substation to Supply DAF

The final system design proposed in this study is to connect the PV plant to the HT side of the substation. Meters need to be installed at the beginning of the DAF on the LT side of the substation and at the point of interconnection of the PV plant and the HT side of the substation (Figure 17). It is possible to virtually determine how much solar-based generation is being supplied to the grid and to the DAF based on the load of the DAF. Subtracting the solar generation from the DAF load results in the amount of electricity being imported from the grid. However, it is not possible to know whether the solar-based generation is physically going to

the DAF or not. This design is suitable for the developer as well because the PV plant generation, and hence, revenue is unaffected by faults on the LT side of the substation; i.e., in DAFs. The LCOE of this system design is only ~12% more than the APPC of Karnataka DISCOMs (Table 7) thereby making it the **most economically viable** option to supply solar-based generation to DAFs in the state.

However, this system design is **dependent on accurate measurements** being recorded by meters. The idea of feeder segregation was conceived based on the notion that meters will keep track of how much electricity is being consumed by the agricultural sector. This would lead to better accounting and calculation of the annual subsidy. Unfortunately, the reality is that the meter readings are unreliable and the annual subsidy claims of the DISCOMs are skewed. This is the primary reason for planning to use small scale ground-mounted PV plants (1-5 MW) to supply the DAFs which are close to the point of generation and provide accurate monitoring and measurements when it comes to recording supply and demand numbers in the DAFs. The success of this scheme hinges on whether the meters – which were initially installed in DAFs – actually reflect the true consumption in the agricultural sector or not.

The objective of this project is to make informed policy recommendations and construct an implementable roadmap for the Energy Department to implement a programme for supplying DAFs with solar-based generation. It is important to compare all the proposed system designs in this study and associated results and determine the most suitable for widespread adoption in Karnataka. A SWOT analysis has been performed for these system designs to assess the pros and cons and arrive at the acceptable choices. This is summarised in Table 8.

Table 8: SWOT analysis of system design options to supply DAFs in Karnataka with solar-based generation

<i>System Design Option</i>	Strengths	Weaknesses	Opportunities	Threats
<i>Off-grid PV with battery storage</i>	<ul style="list-style-type: none"> • Technically supply DAFs with only solar-based generation • Accurate accounting • More control over switching on and off of supply to DAFs 	<ul style="list-style-type: none"> • Economically unviable with LCOE>3.5 times APPC • Battery needs to be replaced every 4-5 years • Wastage of excess generation due to oversizing of PV/battery 	<ul style="list-style-type: none"> • Batteries might become cheaper in the future • Improvement in energy intensities and minimum state of charge requirements for batteries in the future 	<ul style="list-style-type: none"> • Battery/array malfunction will lead to disruption in supply to DAFs • Farmer disgruntlement due to reliability issues
<i>Off-grid PV with battery storage and scheduling</i>	<ul style="list-style-type: none"> • Technically supply more than one DAFs with only solar-based generation • Accurate accounting • More control over switching on and off of supply to DAFs 	<ul style="list-style-type: none"> • Economically unviable with LCOE>4 times APPC • Battery needs to be replaced every 4-5 years • Wastage of excess generation due to oversizing of PV/battery 	<ul style="list-style-type: none"> • Batteries might become cheaper in the future • Improvement in energy intensities and minimum state of charge requirements for batteries in the future 	<ul style="list-style-type: none"> • Battery/array malfunction will lead to disruption in supply to DAFs • Farmer disgruntlement due to reliability issues • Unwillingness of farmers and political implications to have supply shutdowns for more than a day

<p>Off-grid PV with water storage</p>	<ul style="list-style-type: none"> • Technically supply more than one DAFs with only solar-based generation • Accurate accounting • More control over switching on and off of supply to DAFs 	<ul style="list-style-type: none"> • Economically unviable with LCOE>3 times APPC • Possible to implement only in areas with high water tables and river-canal based irrigation practices • Large size pumps required to achieve economies of scale • Wastage of excess generation due to oversizing of PV 	<ul style="list-style-type: none"> • Co-operative of farmers can lead to reduction in costs due to sharing model 	<ul style="list-style-type: none"> • PV array malfunction will lead to disruption in supply to DAFs • Farmer disgruntlement due to reliability issues • Unwillingness of farmers to have co-operative model
<p>Grid-connected PV with storage and one-way export</p>	<ul style="list-style-type: none"> • Technically supply more than one DAFs with only solar-based generation • Accurate accounting • More control over switching on and off of supply to DAFs 	<ul style="list-style-type: none"> • Economically unviable with LCOE>2 times APPC • Technology to allow one-way export using relays does not exist in the distribution sector at present 	<ul style="list-style-type: none"> • Batteries might become cheaper in the future • Sophisticated technologies might be developed in the future to allow smoother operation of relays for one-way export option 	<ul style="list-style-type: none"> • PV array malfunction will lead to disruption in supply to DAFs • Farmer disgruntlement due to reliability issues • Developer might divert generation to grid to secure revenue from sales
<p>Grid-connected PV plant connected directly to DAF</p>	<ul style="list-style-type: none"> • Economically viable with LCOE ~17% more than APPC 	<ul style="list-style-type: none"> • Technically DAFs import power from the grid which will lead to discrepancies in meter readings and hence skewed 	<ul style="list-style-type: none"> • Sophisticated technologies might be developed in the future to allow faster switching of PV to grid during faults in 	<ul style="list-style-type: none"> • Local pressure might lead to DAFs being kept on even after seven hours thereby continuing

<p><i>at LT side of substation</i></p>	<ul style="list-style-type: none"> • Grid can provide backup power during times of low generation from PV plant 	<ul style="list-style-type: none"> • annual compensation claims from DISCOMs • DAFs are prone to faults and this means that the developer is at risk of losing generation and hence revenue during outages • Requires careful monitoring of DAFs by DISCOMs and increase in the number of meters at different junctions 	<ul style="list-style-type: none"> • DAFs thereby reducing developer risks • Improvements in meter technologies in the future might lead to lesser number of meters for this system design 	<ul style="list-style-type: none"> • the existing practice of overdrawing of power • Developer might renege on terms due to faults in DAFs and higher risks in terms of securing revenue from generation sales
<p><i>Grid-connected PV plant connected at HT side of substation to supply DAF</i></p>	<ul style="list-style-type: none"> • Economically viable with LCOE ~12% more than APPC • Grid can provide backup power during times of low generation from PV plant • Reduction in developer risk by removing connection to LT side which has DAFs prone to faults 	<ul style="list-style-type: none"> • Technically DAFs import power from the grid which will lead to discrepancies in meter readings and hence skewed annual compensation claims from DISCOMs • Requires careful monitoring of DAFs by DISCOMs and increase in the number of meters at different junctions 	<ul style="list-style-type: none"> • Improvements in meter technologies in the future might lead to lesser number of meters for this system design 	<ul style="list-style-type: none"> • Local pressure might lead to DAFs being kept on even after seven hours thereby continuing the existing practice of overdrawing of power

8. Reflections and Conclusion

This section presents the key findings of this study, the wider implications of using solar-based generation to supply DAFs in Karnataka and highlights the issues and benefits of each proposed system design.

8.1. Reflections

- In recent KERC orders, the net/gross-metering rate for rooftop photovoltaic (RTPV) plants has been reduced to INR 3.56/kWh (KERC 2018h) whereas wheeling and banking charges for open-access using solar-based generation have been increased by INR 1.25-2/kWh (KERC 2018a). This makes solar energy projects less attractive for prospective industrial, commercial and residential consumers in terms of business cases. KERC has been pressurised to revise these rates not only because global PV prices have been declining steadily, but also because DISCOMs are claiming that they are losing increasing amounts of money every year because of supplying free power to the agricultural sector. DISCOMs are unable to recover this loss of revenue even through the cross-subsidy model where other consumer categories pay higher than the actual rate.
- The agricultural sectors in Karnataka and many other states have borne the brunt when it comes to allocation of AT&C and revenue losses for DISCOMs. Owing to insufficient availability of ground-level data and other societal and political constraints, this sector continues to take a heavy toll on DISCOM finances. Inefficiencies, power thefts and other losses are bundled into the agricultural sector and DISCOMs claim thousands of crores as annual compensation from the respective State Electricity Regulatory Commissions (SERCs). Karnataka DISCOMs claims are expected to cross INR 10,000 crores in this financial year.
- On the other hand, farmers justify the free supply of power to the agricultural sector on the basis of low annual incomes and low product prices in the downstream markets. Rough estimates show that if farmers were to be charged even INR 1/kWh for power supply, then the cost of common crops would rise by 10% for end consumers.
- In order to alleviate the issues of the stifling rates for RTPV and open-access for renewables, and the losses arising out of free electricity for farmers, it is essential to

bring technical, economic and regulatory reforms in the agricultural sector when it comes to power supply.

- Some states in India including Karnataka have tried to rectify the situation by segregating agricultural feeders from other loads in an effort to restrict power supply to 7-8 hours for IP sets to reduce indiscriminate use of electricity. The premise was to provide stable power supply for 7-8 hours and to reduce the financial losses for DISCOMs by accurately measuring the amount of power being fed into DAFs. However, while some states reported improvements in voltage and power quality in the feeders, most states have not had beneficial financial outcomes as annual compensation claims continue to rise. This is primarily because of lack of monitoring, incomplete feeder segregation and incorrect meter readings. Efforts have not been made to redress this issue. Also, farmers have not informed authorities while replacing older IP sets with higher capacity IP sets in order to draw water from the ever-decreasing underground water levels and continue to receive free power.
- The first step towards amending the situation with the agricultural sector is to accurately assess the demand on each DAF. DISCOMs need to take the initiative of keeping records of the number of IP sets per feeder, the rate of annual additions of IP sets in the feeders along with their capacities to predict future demand, and the hours of usage of IP sets based on the regions' cropping patterns and irrigation requirements. Information about the latter can be obtained from the respective agricultural and water departments. DISCOMs also need to maintain the meters on each of these DAFs and keep correct readings in the database.
- Once the demand is accurately determined, innovative solutions need to be developed to ensure that power is generated and consumed locally to reduce technical losses. It is in this regard that small ground-mounted PV plants (1-5 MW) in Karnataka can play a pivotal role. Since Karnataka has a progressive policy of restricting solar capacities in a taluka to 200 MW and the solar radiation profiles across the state are favourable for power generation, it is possible to link these distributed solar plants to the agricultural demands in the vicinity. However, since solar energy is intermittent, a backup source is required to maintain stable power supply to DAFs. This can either be storage technologies or the grid. This study is to analyse the most optimal way that these distributed solar plants can cater to the DAF demands in the future.

8.2. Conclusion

- Surveys were conducted across the state of Karnataka to cover all the prime agricultural zones. Load data of DAFs of 20 substations (4 from each DISCOM except MESCOM) were collected to construct the load curves and assess demand in each of the DAFs. The data revealed that the loading pattern on the DAFs, irrespective of geographical locations, depended on the seasonal variations and specific crop requirements. Hence, constant load demand was not observed throughout the year. An interesting observation in these load profiles was that while most DAFs receive 6-8 hours of power supply, it is not continuous. The supply lasts for 3-4 hours during the daytime when the demand is high (most farmers switch on their IP sets) and 3-4 hours late at night when the demand is lesser (fewer farmers keep their IP sets on) (Figure 19). Another anomaly was the spikes in demand in certain period of the year (~40 days) when the load was 60-70% more than the rest of the year. This is because of the aforementioned seasonal variations and specific crop requirements for higher water consumption.
- The load curve was then reconstructed to shift the demand to the daytime for seven hours from 10 AM to 5 PM (Figure 20). This was done to align agricultural demand to the solar generation time window. Surveys showed that the farmers also prefer power supply during the day when they are working in the fields. The projected annual load curve was then constructed by combining the shifted load curves for 365 days (8,760 hours). The projected annual load curve considered a 2% annual increase in demand with 2016-17 being the baseline year. This was capped after 5 years and the resultant load curve was constructed after accounting for the spikes in demand in the specific durations of the year (Figure 21). This is a **limitation** in terms of the accuracy of the results of this study because there is not enough reliable data available to accurately project demand on DAFs.
- Various system designs were developed to use solar-based generation to supply the projected annual load curves of each DAF. To begin with, off-grid systems were designed to ensure that DAFs are supplied only with solar-based generation. The motive behind this was to disconnect the grid completely from DAFs, thereby eradicating the possibility of unreliable data and other external forces related to the grid. The intention was also to analyse the feasibility of using 100% renewable energy for the agricultural sector in Karnataka.

- **Off-grid PV with battery storage** was the first configuration that was analysed. Although the results show that technically such a system can meet the demand of DAFs, the costs are prohibitively high. The spikes in demand lead to oversizing of the PV/battery capacity which in turn leads to higher costs because there is excess generation for 30-65% of the year which goes to waste because of the off-grid nature of the plant. Moreover, at present, battery costs are really high and add to the LCOE of the system. The LCOE of this system design ranges from INR 11-25/kWh whereas the APPC of Karnataka DISCOMs is INR 3.56/kWh, thereby rendering this system **economically unviable**.
- Interviews with agriculturalists, farmers and researchers revealed that there is no need to provide power to DAFs every single day of the year. This led to the design of **off-grid PV with battery storage and scheduling** which allows one PV plant with battery storage to supply two or more DAFs (dependent on geographical location and cropping patterns) with a scheduling algorithm (either alternate days or every third day). Contrary to expectations, the results of this study showed that the optimal system size led to 25-75% excess generation with the LCOE ranging between INR 12-30/kWh making this system design **economically unviable** as well. There are also potentially other constraints with this system design such as farmer and political opposition to DAFs being inactive for over a day.
- Since the final objective of the study is to provide farmers with water for irrigation purposes, a system design was developed with **off-grid PV with water storage** instead of battery storage to reduce system costs by eliminating the need for expensive batteries. Results of this study reveal that the amount of water that is needed to be stored in order to cater to the spikes in demand is more than 50% of the requirement for more than 300 days a year. This leads to excess generation from the oversized PV plant which translates to a high LCOE of INR 9-12/kWh. Although this is an improvement from the previous two off-grid designs, it is still **economically unviable** from a DISCOMs perspective to procure power at these rates.
- It is clear from the findings of the three previous system designs that unless the excess generation is utilised in some way, off-grid designs with any form of storage cannot be used to supply DAFs in Karnataka with solar-based generation. A theoretical **grid-connected PV with battery or water storage with one-way export option** system design was developed to allow this excess generation in the three previous configurations to

be exported to the grid through reverse power relays. This reduced the LCOE of the battery-based systems to INR 7-17/kWh, battery and scheduling to INR 6-23/kWh, water storage to INR 5.5-8/kWh. To **ensure that only solar-based generation** is used to supply DAFs in Karnataka, this system design is the **most viable** even though the LCOE is still higher than the APPC of DISCOMs. However, there is a need to develop a commercial product in the distribution sector which allows this relay based one-way export to the grid in times of excess generation.

- In a bid to further reduce the costs of using solar-based generation to supply DAFs in Karnataka, a compromise was made in the form of developing system designs with ***grid-connected PV with direct injection to DAFs at the LT side of substations*** and ***grid-connected PV at HT side of substations***. The **limitation** of these system designs is that instead of the battery/water storage, the grid acts as the backup and supplies power to DAFs during times of low solar-based generation. Results of this study reveal that the grid supplies power to the DAFs only 10-20% and 10-14% of the time for these two designs respectively. The LCOE of the system designs range from INR 4-5/kWh and INR 3.8-4.7/kWh respectively making them economically viable. However, accurate metering and monitoring – which has been a problem in the past – is required for both these system designs. In the case of direct injection to DAFs, DISCOMs need to closely monitor the DAFs for faults and act promptly to switch the PV plant to supply power to the grid. This poses a risk of generation and revenue loss for the developer in spite of the theoretical benefit of closer control over supply to the DAFs. For PV plants connected at the HT side of substations, the developers' risk of generation and revenue loss due to faults in DAFs is removed. However, DISCOMs need to ensure that the meter readings – at both the PV plant and the DAFs and other feeders emanating from the substations – are recorded accurately.

These conclusions led to an implementable roadmap for the Energy Department for using solar-based generation to supply DAFs in Karnataka. This is presented in the next section.

9. Recommendations

The final chapter of this report focusses on the recommendations that follow from the findings of this study and is framed as an implementable roadmap for the Energy Department of GoK to supply DAFs with solar-based generation in the near future.

9.1. Roadmap for Supplying DAFs in Karnataka with Solar Based Generation

The findings of this study show that the most economical solution is to **connect a PV plant to the HT side of the substation** and virtually supply the DAFs emanating from the substation with solar-based generation. This requires accurate metering and monitoring at the PV plant, connection point at substation and the respective DAFs. The second suitable design option is to **connect the DAF directly to a solar PV plant at the LT side of the substation**. This requires careful monitoring of faults in the DAF by DISCOMs and prompt action to switch the solar-based generation to flow to the grid in case of faults. Both of these design options involve using the grid as a backup during times of low solar generation or fluctuations due to the inherent intermittent nature of solar radiation. The most cost-effective design option which ensures that only solar-based generation is used to supply DAFs is the **grid-connected PV plant with storage and one-way export option**. The roadmap involves testing all these three technologies as pilots in the initial stages of the programme to evaluate the potential for widespread adoption in the state.

9.1.1. Pilot Projects & Scalability

To begin with, the Energy Department can identify 10% of the DAFs across DISCOMs to test the two grid-connected options, viz. connecting PV plant to the HT side of the substation and connecting PV plant directly to the DAF at the LT side of the substation. Substations with existing solar plants connected at the HT side of the substation can be chosen for 5% of the feeders to reduce costs and efforts. The remaining 5% can be connected directly to existing 1-3 MW solar plants under the Farmers' Scheme². In both of these pilots, new meters should be installed at appropriate points in the electrical circuit to record performance data. These pilots can run for two years and monthly audits need to be performed to monitor meter readings. During this timeframe, if the readings reflect the true supply and demand numbers and reduce

² Karnataka Farmers' Scheme for Solar - <http://kredlinfo.in/Scrollfiles/farmer%20final%20for%20website.pdf>

the annual compensation claims, then these two technologies can be scaled up in the rest of the state. Moreover, in the case of the second option, developer satisfaction based on DISCOM co-operation – in terms of switch over of supply to grid during faults in DAFs, and continuity of revenue – is essential for scalability across the state.

However, if the readings are still skewed and there is no improvement to the current situation of DAFs in Karnataka, then the third system design, viz. grid-connected PV with storage and one-way export, will need to be deployed across the state. It is expected that the costs of battery storage will reduce in the next two years and this should reduce the LCOE of these systems to less than INR 5/kWh. Since there is no commercial product available in the market at present to allow for one-way export to the grid during periods of excess generation, the configuration needs to be tested physically on two DAFs on a pilot basis – one with battery storage and the other with water storage. In these two pilots, different relay logics will be tested to arrive at the suitable logic to allow for seamless one-way export to the grid.

9.1.2. Policy & Regulatory Framework

- The present policy of supplying 7 hours of electricity to DAFs *in two phases* needs to be changed to provide 7 hours of *continuous supply* to DAFs from 10 AM to 5 PM every day, with solar-based generation.
- Regulations need to be introduced for farmers to update official records of individual IP sets (age, hours of usage and size). Farmers will also be required to pay a nominal rate (~INR 0.25-50/kWh) to avoid electricity wastage.
- Provisions need to be made in the existing solar policy of the state to reconnect/reconfigure existing solar plants to supply DAFs with existing PPA rates for developers. Grid-connectivity standards and protocols for updated system designs need to be established. Metering mechanisms have to be changed to incorporate more meters at strategic junctions to allow developers to be compensated adequately for their generation.
- For upcoming plants and capacities to be tendered in the future, the solar policy should include clauses of connecting plants directly to the DAFs and to the HT side of the substations with appropriate metering and risk reduction mechanisms such as offtake guarantee for the developer

- Regular energy audits by reliable third-party organisations have to be undertaken to monitor progress of projects and performance of plants and verify meter readings. This is one of the most important components for evaluating the success of the programme in the long run.

9.1.3. Actor Networks and Roles

To ensure that the system programme is implemented holistically and successfully, efficient actor networks with clearly defined roles and responsibilities need to be established.

The Energy Department needs to play an anchoring role throughout the duration of the programme. Substations and DAFs need to be identified for the pilot study. 10% of the total number of DAFs for implementation also need to be chosen. The Energy Department will also need to work with KREDL to determine which existing solar plants need to be connected to the DAFs identified for the pilot. Based on the success of the pilots, the department needs to revise the state solar policy for widespread adoption of solar-based generation to supply DAFs. They will also need to employ third party organisations to conduct regular energy audits and keep an updated database of all meter readings.

KREDL and the DISCOMs need to work together, along with developers, to implement and maintain the pilots in the first two years. KREDL will also need to take the initiative of managing future tenders for distributed smaller ground-mounted plants (1-5 MW). They will use DARPAN – the web-based GIS tool developed by CSTEP – to help developers identify suitable land parcels for these projects.

DISCOMs along with Karnataka Power Transmission Corporation Limited (KPTCL) will need to upgrade substations with higher capacity transformers in locations suitable for project implementation. DISCOMs will also need to pay developers on time and enable them to evacuate power to the grid in case of faults in the DAFs. DISCOMs will have to maintain accurate meter readings. KERC will hold DISCOMs responsible and accountable for any discrepancies found in records through the energy audits.

Farmers will need to provide DISCOMs with information about their IP set replacements and capacity increases. They will also need to pay the nominal rate for electricity consumption to ensure proper utilisation of electricity and water resources.

CSTEP will act as a knowledge and implementation partner for the Energy Department throughout the course of this programme.

This complete roadmap has the potential to change the way power is being supplied to the agricultural sector in Karnataka. The expected outcomes are:

- exponential reductions in annual subsidy claims made by DISCOMs
- decrease in the rate of water table depletion or increase in water levels in certain locations
- widespread adoption of solar power in the state without additional expenditures for infrastructure development for the Energy Department, KREDL and DISCOMs
- reduction in cross-subsidy charges for other consumer categories.

Bibliography

ADB. 2011. “India: Madhya Pradesh Energy Efficiency Improvement Investment Program.” Initial Environmental Examination for Feeder Separation Project (Tranche1) RRP IND 43467. Asian Development Bank. <https://www.adb.org/sites/default/files/linked-documents/43467-014-ind-ieeab.pdf>.

Bhatt, Sonal. 2008. “Impact of Jyotigram Scheme on Rural Life and Economy in Gujarat: A Case Study of Four Villages in Anand District.” *Journal of Rural Development* 27 (3): 501–22.

Brabeck-Letmathe, Peter. 2014. “Jyotigram Yojana – a Step towards More Sustainable Energy and Water Management.” International Water Management Institute. *Water Challenge: A Blog by Peter Brabeck-Letmathe* (blog). April 25, 2014. http://www.iwmi.cgiar.org/News_Room/iwmi-in-the-news/2014/05/jyotigram-yojana_a-step-towards-more-sustainable-energy-and-water-management.pdf.

Electricity Ombudsman. 2017. “Ombudsman Order Case No. : EOR 394/2017.” Jaipur: Rajasthan Electricity Regulatory Commission. <http://rerc.rajasthan.gov.in/OmbudsOrders/OBOrder382.pdf>.

Energy Department. 2016. “Schemes of the Central & State Government.” Government of Karnataka. April 2016. <http://www.karnataka.gov.in/energy/english/Pages/Schemes.aspx>.

FE Online. 2017. “Haryana Agricultural Sector to Get 10 Hours of Electricity Every Day from Nov 1: Manohar Lal Khattar.” *Financial Express*, November 1, 2017. <https://www.financialexpress.com/india-news/haryana-agricultural-sector-to-get-10-hours-of-electricity-every-day-from-nov-1-manohar-lal-khattar/915410/>.

FoR. 2014. “Framework to Draw up a Scheme at National Level for Feeder Segregation of Rural and Agricultural Consumers and Suggest Measures on Effective Metering.” Forum of Regulators. <http://www.forumofregulators.gov.in/Data/WhatsNew/Framework.pdf>.

GENSOL. 2017. “MAHAGENCO Solar AG Feeder Scheme - Highlights.” GENSOL Consultants Pvt. Ltd. http://www.eqmagpro.com/wp-content/uploads/2017/11/Revised_PPT_-Solar-AG-Feeders-Mahagenco_18.11.17.pdf.

IWMI. 2011. “Innovative Electricity Scheme Sparks Rural Development in India’s Gujarat State.” Success Stories. International Water Management Institute.

http://www.iwmi.cgiar.org/wp-content/uploads/2013/03/Issue_9-Innovative-electricity-scheme-sparks.pdf.

Karnatakastat. 2018. “Gross State Value Added (GSVA) at Factor Cost by Industry of Origin in Karnataka.” <http://www.karnatakastat.com/economy-data/8/national-income/175/gross-state-domestic-product-gsd/12081/stats.aspx>.

KERC. 2018a. “Discussion Paper: Revision in Open Access Rates for Renewable Energy Projects in Karnataka.” Karnataka Electricity Regulatory Commission.

KERC. 2018b. “BESCOM Tariff Order 2018.” Bengaluru: Karnataka Electricity Regulatory Commission. <http://www.karnataka.gov.in/kerc/courtorders2018/6-BESCOM%20%20-%20%20CHAPTER%20-%204.pdf>.

KERC. 2018c. “CESC Tariff Order 2018.” Bengaluru: Karnataka Electricity Regulatory Commission. <http://www.karnataka.gov.in/kerc/courtorders2018/6-CESC%20-%20CHAPTER%20-%204.pdf>.

KERC. 2018d. “GESCOM Tariff Order 2018.” Bengaluru: Karnataka Electricity Regulatory Commission. <http://www.karnataka.gov.in/kerc/courtorders2018/6-GESCOM%20-%20CHAPTER%20-%204.pdf>.

KERC. 2018e. “HESCOM Tariff Order 2018.” Bengaluru: Karnataka Electricity Regulatory Commission. <http://www.karnataka.gov.in/kerc/courtorders2018/6-HESCOM%20-%20CHAPTER%20-%204.pdf>.

KERC. 2018f. “HRECS Tariff Order 2018.” Bengaluru: Karnataka Electricity Regulatory Commission. <http://www.karnataka.gov.in/kerc/courtorders2018/4-HRECS%20-%20CHAPTER%20-2.pdf>.

KERC. 2018g. “MESCOM Tariff Order 2018.” Bengaluru: Karnataka Electricity Regulatory Commission. <http://www.karnataka.gov.in/kerc/courtorders2018/6-MESCOM%20-%20CHAPTER%20-%204.pdf>.

- KERC. 2018h. “Revision in Gross/Net-Metering Rates for Rooftop Solar Plants in Karnataka.” Karnataka Electricity Regulatory Commission.
- Livemint. 2014. “Govt to Allocate Rs. 75,600 Crore for Rural Electrification: Goyal,” September 8, 2014. <https://www.livemint.com/Politics/vqgvbm3yK20A5gqMg7KrpM/NDA-to-spend-Rs75600-crore-to-provide-24x7-power-to-rural-h.html>.
- MAHADES. 2016. “Limited Tender for Conducting Evaluation Study of Capital Investment in Gaothan Feeder Separation Scheme and Infrastructure Plan-I Implemented by Energy Department, GoM.” Directorate of Economics and Statistics Planning Department, Government of Maharashtra.
<http://www.mahades.maharashtra.gov.in/files/noticeboard/Tender%20Doc.pdf>.
- MAHADISCOM. 2007. “Jyoti Gram Yojana: Boon to Rural Gujarat.” Maharashtra State Electricity Distribution Company Limited.
http://mahadiscom.com/emagazine/feb06/JGY_Writeup.pdf.
- MERC. 2012. “Order for CASE No. 129 of 2011.” Maharashtra Electricity Regulatory Commission.
http://www.mercindia.org.in/pdf/Order%2058%2042/Order_Case%20No.%20129%20of%202011_23%20feb2012.pdf.
- MERC. 2017. “Order for CASE No. 120 of 2016.” Maharashtra Electricity Regulatory Commission. <http://www.mercindia.org.in/pdf/Order%2058%2042/Order-120%20of%202016-20062017.pdf>.
- MNRE. 2018. “KUSUM Scheme – Harnessing Solar Power for Rural India.” Press Information Bureau. <http://pib.nic.in/newsite/PrintRelease.aspx?relid=177489>.
- MoP. 2016a. “24X7 Power for All: Madhya Pradesh.” Ministry of Power.
https://powermin.nic.in/sites/default/files/uploads/joint_initiative_of_govt_of_india_and_madhya%20pradesh.pdf.
- MoP. 2016b. “Power for All: Telangana State.” Ministry of Power.
https://powermin.nic.in/sites/default/files/uploads/Power_For_All_4_12_Final_Telangana_Signed.pdf.

MoP. 2018. “UDAY Dashboard for Telangana.” UDAY. May 2018.

<https://www.uday.gov.in/state.php?id=20&code=telangana>.

NREL. 2013. “India Direct Normal & Global Horizontal Irradiance Solar Resources.”

National Renewable Energy Laboratory. <https://data.nrel.gov/submissions/43>.

PowerLine. 2017. “Feeder Separation: Ensuring Better Load Management and Reliable Supply,” May 2017. <https://powerline.net.in/2017/05/07/feeder-separation/>.

Prayas (Energy Group). 2016. “Solar Powered Agriculture Feeders: A Conceptual Framework.” Pune: Prayas.

http://www.prayaspune.org/peg/publications/item/download/621_dc2ddc8470a54cdd76c79584a8050fe2.html.

PSERC. 2013. “Loss Reduction Initiatives in Punjab.” Punjab State Electricity Regulatory Commission. <http://www.forumofregulators.gov.in/Data/WhatsNew/PSERC.pdf>.

PTI. 2018. “Cabinet Nod Soon for Rs 50,000 Crore KUSUM Scheme on Solar Farming.”

Economic Times, April 3, 2018.

<https://energy.economictimes.indiatimes.com/news/renewable/cabinet-nod-soon-for-rs-50000-crore-kusum-scheme-on-solar-farming/63597665>.

REC. 2015. “Guidelines: Deendayal Upadhyaya Gram Jyoti Yojana (DDUGJY).” Ministry of Power. http://www.ddugjy.gov.in/portal/memo/DDUGJY_Guidelines.pdf.

Shah, Tushaar, Sonal Bhatt, R.K. Shah, and Jayesh Talati. 2008. “Groundwater Governance through Electricity Supply Management: Assessing an Innovative Intervention in Gujarat, Western India.” *Agricultural Water Management* 95 (11): 1233–42.

<https://doi.org/10.1016/j.agwat.2008.04.006>.

World Bank. 2014. “Lighting Rural India: Load Segregation Experience in Selected States.”

81485. Asia Sustainable and Alternative Energy Program. World Bank.

<http://documents.worldbank.org/curated/en/220801468042879882/pdf/814850REVISED00Box0379832B00PUBLIC0.pdf>.

Annexures

Please refer to the compressed .zip file which contains all the relevant data/simulation results/feeder load restructuring/solar plant details in different folders.

Appendix I – Efforts in Other States

Gujarat: Jyoti Gram Yojana (JGY)

This was one of the first efforts in the country to separate agricultural and non-agricultural loads. In the space of three years, 18,065 villages and 9,353 rural suburbs were covered to segregate 1,904 agricultural feeders and required a total investment of INR 1,290 crores (Bhatt 2008) (FoR 2014). Agricultural feeders are provided with a minimum of 8 hours of power supply with minimal voltage fluctuations and electricity is provided at a 75% subsidy to farmers (MAHADISCOM 2007). Reports show that the water levels in most areas rose by 4m (Brabeck-Letmathe 2014) and the consumption for tube-wells and IP sets dropped from 15.7 billion kWh in 2001 to 9.9 billion kWh in 2006 (Shah et al. 2008). While India's GDP contributions from agriculture grew at 2.9% per annum, Gujarat grew at nearly 10% per annum from FY2000 to FY2006 (IWMI 2011). The impact of JGY led to the development of the DDUGJY scheme and uptake in the other aforementioned states.

Andhra Pradesh

Feeder segregation in erstwhile Andhra Pradesh was initiated in the year 2001 making it one of the first programmes in India. The programme started in 2010 with virtual segregation. This involved separation of single phase and 3 phase loads with relocation of DTs with LT lines. Also, rotary switches were used to supply only 2 phases ensuring that IP sets do not run on existing feeders. However, DISCOMs of Andhra Pradesh took up physical segregation to avoid power theft and resolve the issues of faulty metering. As of 2014, 8,878 DAFs were separated by Eastern Power Distribution Corporation Limited (APEPDCL) and Southern Power Distribution Corporation Limited (APSPDCL). This was implemented with an investment of INR 3014 crores (World Bank 2014). Agricultural feeders are provided with a minimum of 7 hours of power supply with minimal voltage fluctuation and electricity is provided at subsidised rates to formers.

Rajasthan: Feeder Renovation Programme (FRP)

Feeder segregation in Rajasthan was implemented to improve the hours of power supply to rural consumers whilst reducing losses. DISCOMs of Rajasthan initiated feeder segregation in year 2005 with virtual segregation of 8,126 agricultural feeders and implementation cost of

INR 4,485 crores (FoR 2014; World Bank 2014). The plan of segregation was to restrict power supply in existing feeders using a roster switch, so that 3-phase power can be supplied to agricultural consumers during the time of demand and rest of the hours are supplied with single phase power supply. In spite of FRP implementation, power is still supplied free of cost to the agricultural sector and has increased pressure on the finance department of Rajasthan as subsidy payments increased due to overconsumption of electricity in the agricultural sector. Recently there have been discussions to restrict power supply to the DAFs for a block of 6 hours a day to alleviate the financial burden of the state (Electricity Ombudsman 2017).

Maharashtra: Gaothan Feeder Separation Scheme (GFSS)

GFSS is a feeder separation programme initiated in 2006 in the state of Maharashtra. The scheme treats existing feeders as agriculture feeders and new feeders have been drawn from substations in Gaothan villages for other categories. The implementation cost is INR 3,080 crores for the segregation of 3,602 feeders (MAHADES 2016). DISCOMs of Maharashtra are providing 8 hours of power supply to IP sets (MERC 2017, 2012).

Maharashtra is the first state in India to consider using solar-based generation for supplying DAFs. The Prayas Energy Group recommended connecting 1-2 MW solar plants to the agricultural feeders through the local substation (Prayas (Energy Group) 2016). The government launched the “Mukhyamantri Agricultural Solar Feeder Scheme” in November 2017 with a target of 1.5 GW solar capacity installations across the state in order to give 12 hours of power during the daytime to farmers through the already segregated agricultural feeders (GENSOL 2017). The farmers are expected to pay INR 1.2/kWh.

Punjab

Punjab’s feeder segregation efforts started in 1996-97 which is the first in India. The programme is spread across 12,428 villages covering 13.75 lakh agricultural consumers. Almost 850 mixed feeders have been segregated with an implementation cost of INR 211.55 crores (FoR 2014; World Bank 2014). The plan of segregation was to provide 24 hours power supply to rural households, industries and commercial establishments. Today, the practice is to provide 8 hours of uninterrupted power supply to the DAFs. However, after segregation of feeders, consumption of non-agricultural loads increased leading to high line losses which has impacted finances of the state DISCOMs (PSERC 2013).

Haryana

DISCOMs of Haryana initiated feeder segregation in 2006 with physical segregation of 1,226 agricultural feeders and implementation cost of INR 573 crores (FoR 2014; World Bank 2014). The plan of segregation is to restrict power supply to agricultural consumers and to improve the stability of the distribution network by increasing supply voltage. Even though feeder segregation started many years back, Haryana is facing delays in completing feeder segregation due to lack of monitoring and adherence to protocol for installations. The government of Haryana intends to provide 10 hours of power supply to the DAFs (FE Online 2017).

Madhya Pradesh

Madhya Pradesh initiated feeder segregation in 2011 with the objective of supplying 24X7 power to all non-agricultural consumers and 8-10 hours of supply to the DAFs through the Atal Jyoti Abhiyan programme. Under DDUGJY, INR 825.49 crores have been sanctioned for separating agricultural feeders. The state government has plans of separating 6,760 feeders with additional funding of INR 1,641 crores (MoP 2016a). The state has sought a 400 million USD multi-tranche loan from the Asian Development Bank (ADB 2011).

Telangana

Feeder segregation in Telangana was initiated in 2015 to provide 24X7 3-phase power supply to industries located in rural areas. The objective is to segregate 4,196 feeders out of which 387 have been completed so far (MoP 2018). The envisaged cost of this programme is around INR 404 crores. The government wants to increase power supply to the DAFs to 9 hours compared to the 7 hours at present (MoP 2016b). However, DISCOMs of Telangana are of the opinion that increasing the density of substations in the form of compact substations is a better option compared to feeder segregation when it comes to reducing distribution losses (FoR 2014).

Kisan Urja Suraksha evam Utthaan Mahabhiyan (KUSUM)

The Central Government is developing KUSUM with the objective of using solar power to supply rural demand which includes DAFs. Ground-mounted grid-connected plants of capacity up to 2 MW can be installed in identified locations to cater to agricultural demand apart from solar pumps, tube-wells and lift irrigation projects (MNRE 2018). The total financial outlay for this scheme is expected to be ~ INR 50,000 crores (PTI 2018).



CENTER FOR STUDY OF SCIENCE, TECHNOLOGY AND POLICY

18 & 19, 10th Cross, Mayura Street, Papanna Layout, Nagashettyhalli, RMV II Stage,
Bengaluru - 560094 Karnataka, INDIA

Website: <http://www.cstep.in/> Email: cpe@cstep.in